



HEAVY ENCLOSED CONDUCTOR SYSTEMS



Basic description

The totally enclosed VAHLE Conductor Rail Trunking Systems have been manufactured since 1925. It is used at dockside cranes, loading bridges, container handling equipment etc. in which overhead installed conductors would be hindering. The ducting system is installed in parallel to the crane track below or above ground and could be adjusted without difficulties to all occurring curves of the crane track.

The flush-mounted version is normally installed in a concrete trench, while in the surface-mounted version the trunking is made of steel. Both cases are entirely covered by steel-plates resting on both sides of the ducting, one side being hinged with negative or surface hinges.

The plates facilitate walking and the system can be used as a pavement in harbours or loading areas. If the duct should be walkable negative hinges are recommended to prevent risk of stumbling.

While driving the crane the cover plates are lifted by the cover plate lifting device only to let the feed cable through.

For maintenance of the conductor rails and collectors single covers could be lifted by simple tools.

Unallowed individual lifting by hand is prevented due to the heavy weight of the plates. This is as well valid for cover plates lifted by the cover plate lifting device due to a safety arrangement.

A practically unlimited number of cranes or other machinery can be supplied by this conductor duct system. It is as well possible to add at a later date additional cranes, assuming that the cross section of the conductor is suitable for this.

The conductor is with its insulators mounted to support brackets, which are installed to the hinge side.

The VAHLE-rails could be arranged lateral – as shown in the following drawing – or standing.

The lateral arrangement should be preferred for maintenance and cleaning of the duct.

Through a later parallel arrangement of cables could a further reducing of the voltage drop be achieved.

To transfer big ratings ducting systems (System EID/C) with middle voltage could be used.

To guarantee the isolating value of middle voltage systems they have to be ventilated.

An extension is possible to both sides of the system.

For concrete expansion gaps are edge protection angles with expansion required.

Due to the variable length of an expansion area, are for each area one set of edge protection angles with overlength to be considered.

If the duct should be driveable the cover plates will be adjusted to the wheel pressure.

The wall anchor have to be welded with the reinforcing bar, to make the edge protection- resp. Track profiles for the max. load suitable. Further the installation is a lot more easy.

Edge protection angles / hinge angles in curve tracks with radii smaller than 130 mm have to be factory bended.

Breaker to separate the conductor in different maintenance areas could be installed.

The internal earthing system (Banderer) of the duct has to be installed on site in max. 50 m distance to the local earthing system (e.g. crane track)

Protection classes

Protection class in the area of the dropped cover plates: IP 2 x

Protection class in the area of the raised cover plates:

- IP 2 x (only with EID-ducts)
- IP 2 x D (only with EID-ducts, design C)
- no IP 2 x exists with lifting cover ducts (below or above surface) with uninsulated conductor rails.

Site barriers

To prevent unauthorized approach to the moving equipment is according to German safety regulations a site barrier in area of the cover plate lifting device has to be considered. This guards as well the people for bruising danger, further it supplies the required protection class. (see above).

Concrete duct with cover plate lifting device

A concrete ducting type A is bordered with edge protection and butt hinges. On the butt hinges are the cover plates with under or above ground hinges installed.

The plate lifting device is fix mounted to the lower part of the crane. Bronze skids and vulcollan coated rollers lift the cover plates and discard them.

The feed cable is guided through the arms of the cover plate lifting device.

A safety protection against unauthorized opening of cover plates is installed.

Max. travel speed: 60 m/min.

Concrete duct with cover plate lifting trolley

To allow a safe guiding of the current collectors a cover plate lifting trolley which is guided on rollers at the edge protection and hinge site is recommended. The towing of the cover plate lifting trolley is made with a coupling, which covers tolerances in the layout of the crane rail to the duct.

Design B:

An the hinge side a U-bracket is used to guide the trolley.

Design C:

In this design the rollers at the hinge site run in a Z-bracket.

Crane tolerances

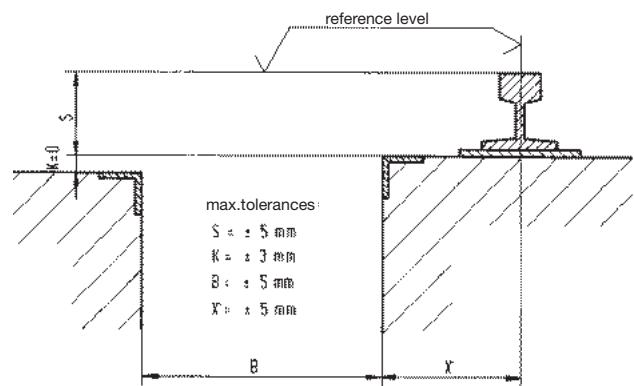

All conductor ducts with short plate cover lifting trolleys are designed for a travel speed of 60 m/min. For higher travel speeds up to 120 m/min we use long plate cover lifting trolleys. The long plate cover lifting trolleys could be used as well for lower travel speeds if according to noise regulations a higher noise protection is required.

The different application options and designs which are mentioned in this catalogue are only a common description. We provide for every single usage a detail documentation. Our customer support service helps you in this case.

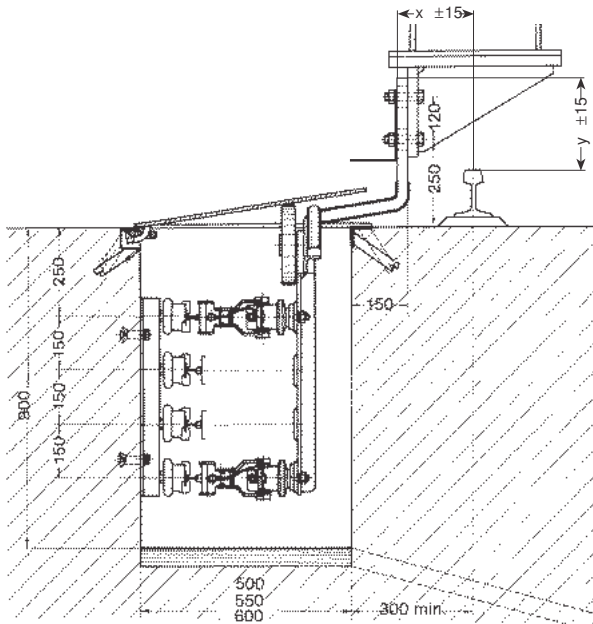

Type A

Steelwork Components:

Edge angle L 60 x 8 mm in 6 m lengths.
Edge angle 75/55 x 7 mm in 6 m lengths with negative hinge halves.
Insulator brackets in 2.5 m distance.
Chequered pivoted cover plates 550 mm wide, 2 m long.

Thickness (mm) ⁽¹⁾	8	10	12
Permissible Wheel load (t)	1	2	5

Conductors:

VAHLE Copperhead Rails F 45, K 45, C 45 or A 45 available from 500 to 1500 Amps.
Standard insulators VDB, max.1000 Volts.

Cover lifting device:

incl. towing arm and VAHLE current collectors GSV series (100, 200, 400 or 800 Amp units available).

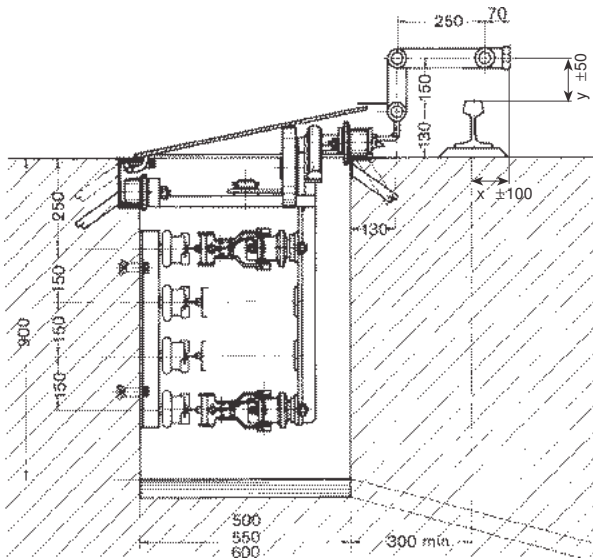

Type B

Steelwork Components:

Edge angel L 60 x 8 mm in 6 m lengths.
Hinge U 140 in 6 m lengths with negative hinge halves.
Insulator brackets in 2.5 m distance.
Chequered pivoted cover plates 550 mm wide, 2 m long.

Thickness (mm) ⁽¹⁾	8	10	12
Permissible Wheel load (t)	1	2	5

Conductors:

VAHLE Copperhead Rails F 45, K 45, C 45 or A 45 available from 500 to 1500 Amps.
Standard insulators VDB, max.1000 Volts.

Cover lifting Bogie:

incl. towing linkage and VAHLE current collectors GSV series (100, 200, 400 or 800 Amp units available).

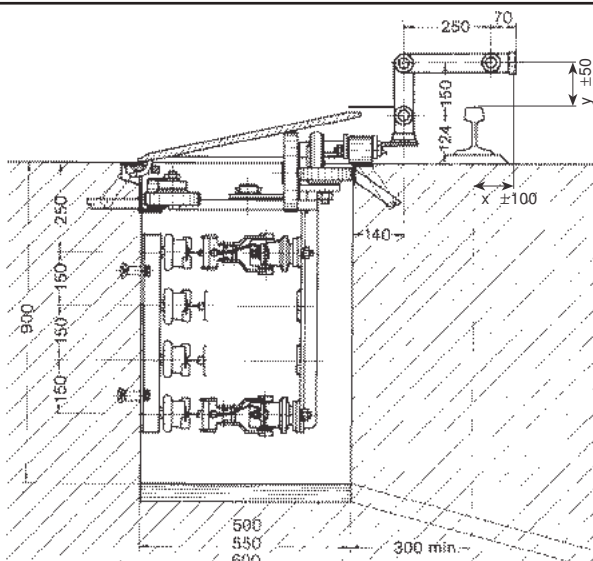

Type C

Steelwork Components:

Edge angle L 60 x 8 mm in 6 m lengths.
Hinge Z 140 mm in 6 m lengths with negative hinge halves.
Insulator brackets in 2.5 m distance.
Plain pivoted cover plates 550 mm wide, 2 m long.

Thickness (mm) ⁽¹⁾	14	16	18	20
Permissible Wheel load (t)	5	8	10	12

Conductors:

VAHLE Copperhead F 45, K 45, AC 45 or C 45 available from 500 to 1500 Amps.
Standard insulators VDB, max.1000 Volts.

Cover lifting Bogie:

Incl. towing linkage and VAHLE current collectors GSV series (100, 200, 400 or 800 Amp units available).

⁽¹⁾ The cover plate dimensions and permissible wheel loads apply to 500 mm width of trench and a contact area of 0,6 x 0,2 m (DIN 1072).
The max. wheel load mentioned is valid for one cover plate.



SURFACE MOUNTED

Surface mounted ducting system in steel design

With subsidence and filled-up areas a surface mounted ducting system is recommended. In this case the conductor duct system is installed to timber or concrete sleepers parallel to the crane track. The 4-pole conductor system is arranged either on both sides or upright-mounted on the bottom of the housing. The current is collected by spring-loaded collectors which are bolted to the cover plate lifting trolley.

With ground swales the coupling of the cover plate lifting trolley covers 300 mm in height and lateral alignments. The unbending of the trench is possible without problems by pushing the sleepers.

Travel speeds see page 2 (concrete duct with plate cover lifting trolley).

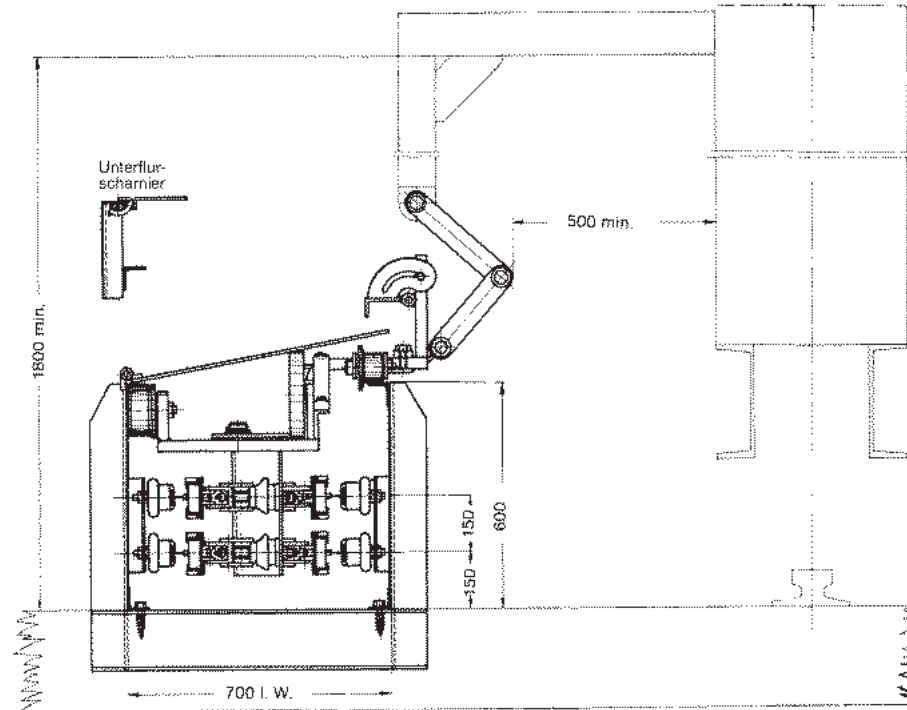

Engineering Data:

Standard steel ducting:

6 m sections - 4 mm sheets
frame- and support-centers: 2 m.
Hinged cover plates of
chequered 6 mm sheets.

Conductors:

VAHLE Copperhead Rails
F 45, K 45, AC 45 or C 45
available from 500 to 1500 amps.
Standard insulators VDB,
max. 1000 Volts, 2 m centers.

Cover Plate lifting Bogie:

incl. coupling and VAHLE current
collector of GSV-series (100, 200,
400 and 800 A) available.



In the application engineering for power supply to cranes mostly contact safe conductors are used. The conductor type FK is a power supply in a contact safe design, which allows the use of conductors of 200 mm² copper cross section. In high installed systems for which contact safety is required normally only a housing is required which covers normal mechanical demands. The basic arrangement of the FK-conductor differs to other systems as the collector trolley has no separate running track has, instead he is running with insulated pvc-rollers on the conductors. Between the rollers are the collectors. Through to this small dimensions for the conductor will be achieved.

Typical applications for the enclosed conductor type FK are O.H.T. Cranes and portal cranes, in particular with heavy dust and outdoor systems.

The conductor type FK consists of folded back sheet of 3 mm width, the holder bracket frame and the top and lower sheet metal housing.

The holder bracket frame gather insert pvc insulators, without metallic parts. The creepage distance of this insulators is 60 mm. They are suitable for conductors with foot width of 35 mm.

The lateral slot for the trolley towing arm and the cable guiding are covered with a neoprene apron. The conductor is rain and snow sealed.

The main dimensions of the 4 pole conductor are 240 mm width and 330 mm height.

This conductor type would be aswell available for more poles. The width dimension has to be changed in this case.

The collector trolleys are equipped with ball-bearing running wheels made of isolating material. The collectors, which are arranged between the running wheels (our type SO), could handle 120 A continuous current. With higher currents more collector per phase could be used. The collector trolley is suitable for travel speeds up to 250 m/min.

The entrainment of the collector trolley through the crane is made with a towing arm, which adjust lateral and height tolerances of the crane to the conductor.

The support distance of the conductor is basically 3.5 m.

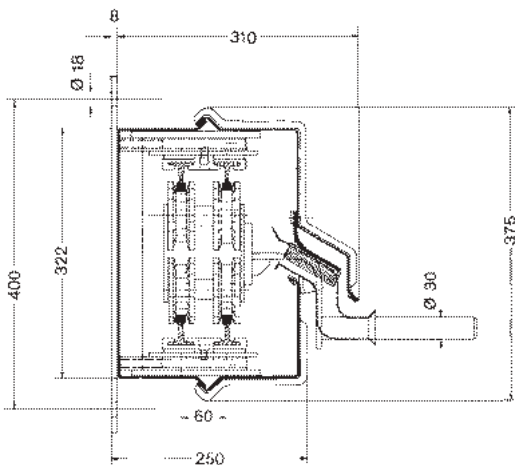

Engineering Data

Enclosure:	Conductors:
Housing with frame work of 3 mm steel sheets - 7 m long	410 A 4 x F 35/ 50
Detachable front covers ⁽¹⁾ of 2,5 mm steel sheets, 3,5 m long	530 A 3 x F 35/100 1 x F 35/ 50
Neoprene sealing strip 4 x 100 mm	730 A 3 x F 35/200 1 x F 35/100
Support centers: 3,5 m	max. 600 V
Current collector trolleys:	Insulator centers:
FKW 120 A, FKW 240 A, FKW 360 A	1,75 m



VAHLE FK-system for container terminal

⁽¹⁾ Hinged front covers if required.



VAHLE CP SYSTEM

The Crashproof (CP) conductor is the combination of a guide rail and a safety electrification system.

In harbour applications, in which full and half portal cranes move on a pier and lorry traffic drive directly to the quay wall, the CP conductor is used as a borderline of the quay to the marine passage way. It will be installed with the thick back approx. 150 mm above ground to the landside while the crane rail is on the quayside.

The conductor consists of a U-shaped housing, in which the conductor rails are installed. The thickness of this housing can be adjusted to the impact load.

An current collector trolley travels before the conductor rail and is guided in the lower part of the housing on a flat iron profile and on the upper part on a copperhead conductor rail. This copper head conductor rail is welded to the housing and is used at the same time as the PE. The craneside is covered with thin plates.

The slot opening for the reach-through of the collector trolley and the cable guiding is covered by a neoprene strip. Accordingly the system is proofed against rainwater and snow sealed and touch safe.

The sections are supplied with installed conductors in length of 6 m. The mounting distance of the housing could be up to 6 m. The joints could cover the length extension of the system.

The standard design of this conductor consists 3 phase rails with a copper cross section of up to 200 mm² and a ground conductor; the rail distance is 65 mm. The main dimensions are 250 mm width and 315 mm height.

With a higher amount of conductor rails the height would be raised with 65 mm for each additional conductor.

With higher load we supply the CP conductor with rails with 400 mm² copper cross section. The rail distance would be then 90 mm with a housing measurement of 300 mm width and 390 mm height.

In both cases are bristle brush collector type BVS (120 A) used. Consumers with higher consumption get more collectors BVS per phase.

We use PVC insulators without metallic parts.

The insulators have a high rigidity and are according the electrical values of ceramic insulating materials. They are suitable for -30°C upto +120°C. The creepage distance consists in the smaller version of 60 mm and with the bigger conductors of 160 mm.

High installed conductors, which would not have an impact on them, are made of thinner plate housings.

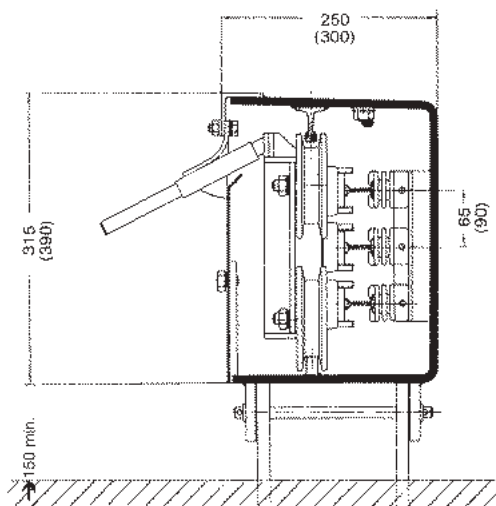

Engineering Data

Enclosure:	Conductors:
Housing of 6, 8, 10 or 12 mm steel sheets 6 m long	330 A 3 x L 20/ 50 1 x F 35/ 50
Detachable front covers of 3 mm steel sheets, 2 m long	450 A 3 x L 20/100 1 x F 35/ 50
Neoprene sealing strip 4 x 100 mm	535 A 3 x C 20/200 1 x F 35/100
Support centers: max. 6 m	max. 600 V
Current collector trolleys: CPW 120 A, CPW 240 A, CPW 360 A	Insulator centers: 1 m



QUESTIONNAIRE FOR VAHLE CONDUCTOR TRENCH SYSTEMS



To the nearest local VAHLE agency:

Date:

Motor data	Crane 1							Crane 2						
	Power kW	Nominal current			Starting current		Type of Motos ⁽¹⁾	Power KW	Nominal current			Starting current		Type of Motos ⁽¹⁾
		A	cos j _N	% ED	A	cos j _A			A	cos j _N	% ED	A	cos j _A	
Hoist motors														
Auxiliary hoist														
Long travel														
Cross travel														

Motor data	Crane 3							Crane 4						
	Power kW	Nominal current			Starting current		Type of Motos ⁽¹⁾	Power KW	Nominal current			Starting current		Type of Motos ⁽¹⁾
		A	cos j _N	% ED	A	cos j _A			A	cos j _N	% ED	A	cos j _A	
Hoist motors														
Auxiliary hoist														
Long travel														
Cross travel														

Mark with * those motors which can run simultaneously.
 Mark with Δ those motors which can start up simultaneously.

⁽¹⁾Use: K for squirrel cage motor
 S for slipring motor
 F for frequency controlled motor

Further remarks: _____

Signature: _____



QUESTIONNAIRE FOR VAHLE CONDUCTOR TRENCH SYSTEMS

To our nearest local VAHLE-agency:

Datum: _____

Questions regarding conductor trench:

1. Type: _____
Below floor level: _____
Surface mounted: _____
2. Indoor: Outdoor:
3. Special site conditions (Humidity, dust, chemical influence, subsidence): _____

4. Max. load on trench cover plates: _____
Pedestrians: _____
Type of vehicles: _____
Wheel load and dimension of wheels: _____
5. Curved run, radius (submit print or sketch): _____
6. Special safety requirements to be observed (mining, chemical industry, etc.): _____

Additional Information: _____

Signet: _____

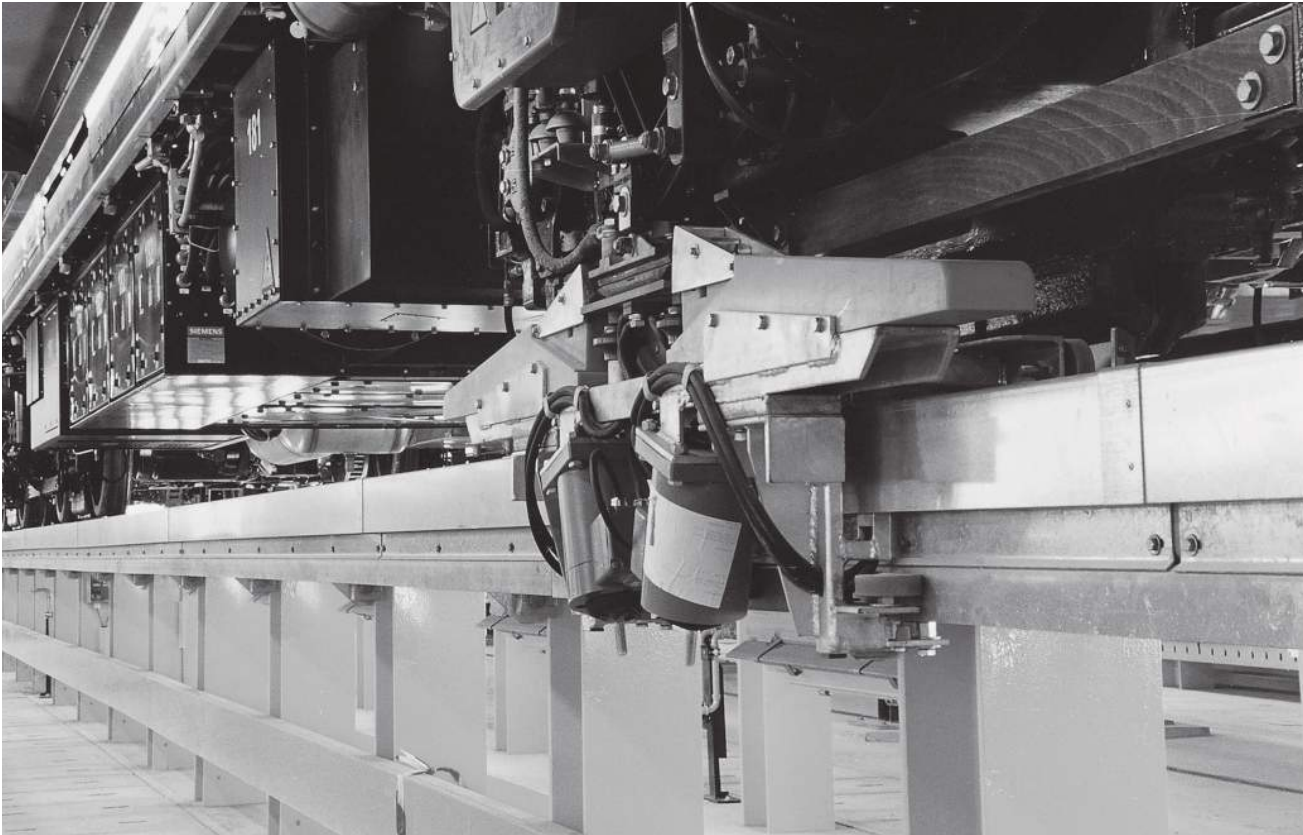

Steel enclosed conductor system for RTS maintenance shop



VAHLE-EID conductor trench for container terminal

Products and Service

Catalog No.

1 Open conductor systems

Open conductor systems

1a

2 Insulated conductor systems

U 10

2a

FABA 100

2b

U 15 - U 25 - U 35

2c

U 20 - U 30 - U 40

2d

3 Compact conductor systems

VKS 10

3a

VKS - VKL

3b

4 Enclosed conductor systems

KBSL - KSL

4a

KBH

4b

MKLD - MKLF - MKLS

4c

LSV - LSVG

4d

5 Contactless power supply

Contactless power supply (CPS®)

5a

6 Data transmission

VAHLE Powercom®

6a

Slotted Microwave Guide (SMG)

6b

7 Positioning systems

VAHLE-APOS®

7a

8 Festoon systems and cables

Festoon systems for □- tracks

8a

Festoon systems for flat cables on I- tracks

8b

Festoon systems for round flat cables on I- tracks

8c

Festoon systems for ◇- tracks

8d

Cables

8e

9 Reels

Spring operated cable reels

9a

Motor powered cable reels

9b

10 Others

Battery charging systems

10a

Heavy enclosed conductor systems

10b

Tender

10c

Contact wire

10d

Assemblies/Commissioning

Spare parts/Maintenance service



certified by DQS according to Din EN
ISO 9001:2008 OHSAS 18001:2007
(Reg. Nr. 003140 QM 08/BSOH)

