



VAHLE

**Enclosed conductor system
KBH**

SYSTEMS IN MOTION



Enclosed conductor system KBH

Content.....	Page
Description of the Conductor system.....	3
Technical description	4
Technical data	5
Joining material, Hangers & End caps.....	8
Brackets	9
End feeds, Line feeds	10
Line feeds	11
Terminal Box	12
Curves, Sealing strip & Cable glands for feeds.....	13
Heating.....	14
Contact sections, turntables & switches.....	16
Transfer funnels & Transfer guides	17

Content.....	Page
Transfer guides & Conductor dead section	18
Removing section.....	19
Anti-Condensation section	20
Expansion section	21
Single Current collector	22
Double collector & Tow arms.....	23
Flexible tow arm	24
Examples for ordering	25
Spare part list	27
Questionnaire	28
Notes.....	30

System photo

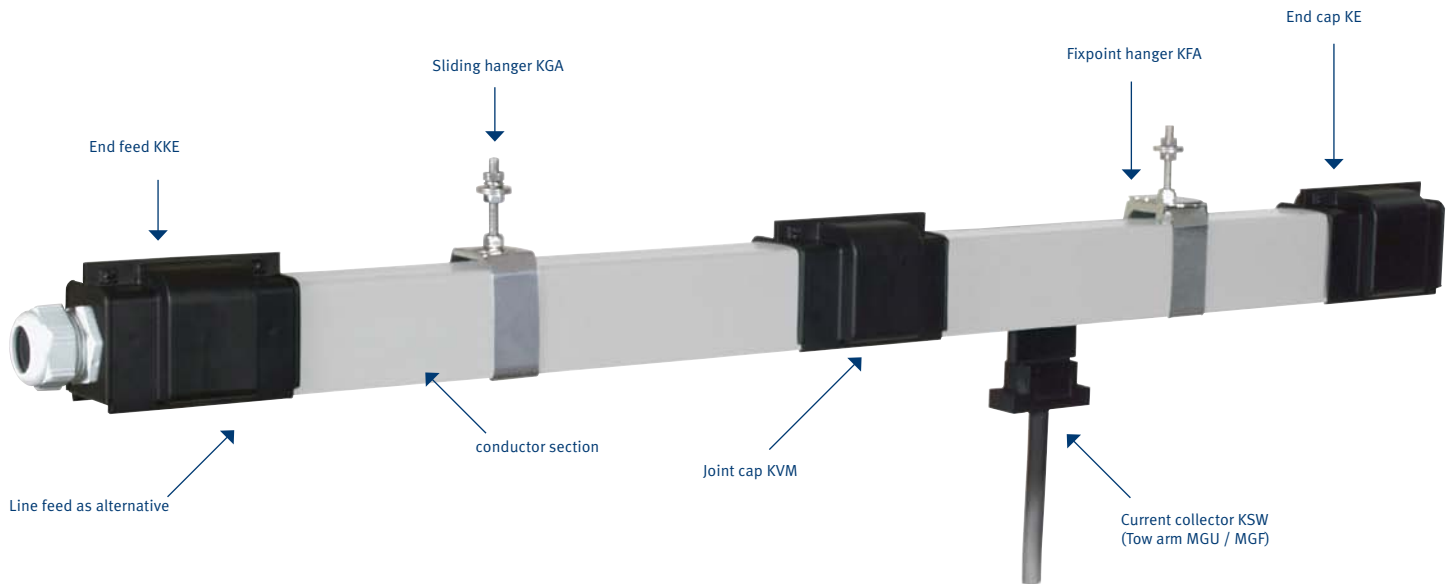

Description of the Conductor system

The Vahle-Powerail KBH is a shock hazard protected conductor system for indoor and outdoor installations. The plastic housing can accommodate different copper profiles.

Type KBHF: in 4- and 5-conductor version, with preassembled copper conductors and spring loaded connectors from 40 to 100 A.

Type KBHS: in 4- and 5-conductor version, with preassembled copper conductors and bolted joints from 40 to 200 A.

A compact design, corrosion resistance and an easy installation are the main characteristics. The KBH complies with VDE, european and international standards as well as accident prevention regulations. It is protected to IP 23 standards. The KBH can be supplied with sealing strip and heating system. The conductor system with sealing strip is protected to IP 24 standards and EN 60529 (0470, part 1) regulation.

Collectors are touch proof only when fully entered into the conductor system. If there is the possibility to touch live parts by hand, ie. collectors that might leave the conductor system during operation, provide safety barrier or disconnect mains. This is valid only for a supply voltage exceeding 24 V AC or 60 VDC.

If a conductor is used as N please note VDE 0100 part 430.

Technical description

Applications

For mobile power consumers like cranes, monorails, electric hoists, machine tools, automated storage and retrieval systems, lighting systems.

Approvals

UL-approved

Housing

Color grey, plastic housing for 4 or 5 conductors.

Standard section 4 m. Other sections are available.

The ground conductor is identified by international color code.

Phase reversing prevented by design of the collector and housing.

Higher number of conductors possible by combination of several conductor systems.

Couplings

Through plastic joint caps.

Feed Sets

Line feeds or end feeds.

End caps

The open ends of the conductor system are closed by end caps for KBHF and KBHS.

Hangers

Support bracket at the crane track (see page 9).

Max. support distance of the conductor at following ambient temperatures:

- Indoor systems and roofed outdoor systems: $\leq 35^{\circ}\text{C} = 2,00\text{ m}$
- Indoor and outdoor systems with and without heating: $> 35^{\circ}\text{C} = 1,33\text{ m}$
- Cold storage: $\leq 0^{\circ}\text{C} = 1,33\text{ m}$

Expansion during temperature fluctuation

The Expansion sections are required to compensate the different expansions between copper conductors and steel- or concrete structures, in varying temperatures without interrupting electrical power. The different expansions between the plastic housing and the copper conductors will be compensated in every joint.

Anti-condensation sections

These sections are used for transfer of the Powerail to outdoor areas to avoid condensation. The conductor system is not separated electrically.

Contact sections, turntables and switches

Conductor sections for working areas and transfer applications see page 17 and 18.

Sectionalizing

Conductor dead sections are electrical interrupts of the conductor. Under normal operating conditions a cross over with collectors to switch the voltage off or on is only allowed with low power ratings (control current).

The conductors can be separated through air gaps (5 mm) or insulating pieces (35 mm). With the air gap the collector carbon bridges the gap, e.g. for mains.

The insulating piece is longer than the carbon and each conductor section can be separated electrically, e.g. for control.

Collectors

The current collectors are made of re-inforced polyester fiberglass, for high strength and light weight. Spring loaded carbon brushes maintain uniform contact. Connecting cables and hinged or flexible towing arms included.

With following system requirements double collectors have to be used:

- Transfers with switches and turntables
- low voltages, frequency controlled drives
- Transmission of data- and/or emergency stop signals
- high electrical loads

The length of the collector cable may not exceed 3 m if the added overcurrent protection device is not designed for the load capacity of this cable. Please refer also to regulations VDE 0100, part 430 and EN 60204-32.

(Note: this might happen in case of several collectors running in one system).

Removing section for collectors

Assembly and disassembly of the collector is possible at the end of the track as well as at the removing section. By opening and closing the sliders at the bottom of the conductor housing the collector can be mounted and demounted easily. Before opening the removing section the conductor system has to be without voltage.

Safety advice

It must be ensured that the arrangement of the conductor system provides minimum distances (0,5 m) between fixed and mobile plant parts (i.e. between conductor rails, collector trolleys and towing arms) so as to avoid the risk of pinching.

Please note: For use in galvanizing and pickling plants, under aggressive conditions and low voltage applications we would appreciate receiving detailed information, especially of the environmental conditions.

For quotations and order processing including conductor systems with curves, dead sections, turntables, switches etc. we require your drawings or sketches. Please use our questionnaire, page 28.

Technical data

Electrical values:

Type	max. continuous current	Nominal voltage (UL)	Dielectric strength	Spec. resistance	Surface resistivity	Leakage resistance
KBH	200 A (at 100% DC)	690 V (600 V)	IEC 60243-1-3 30-40 kV/mm	IEC 60093 $5 \times 10^{15} \Omega/\text{cm}$	IEC 60093 $10^{13} \Omega$	EN 60112 CTI 400-2,7

Mechanical properties:

Type	Flexible strength	Tensile strength	Temperature range (ambient):	Combustibility:	Resistance to chemicals: (at 45 °C)
KBH	75 N/mm ² ± 10%	40 N/mm ² ± 10%	-30 °C up to +60 °C	flame retardant DIN 4102 part 1 class B1; self extinguishing	Gasoline, Mineral Oil, Grease, acid sulfur up to 50%, caustic soda up to 50% and hydrochloric acid up to 25%, concentrated

Consider the voltage drop calculation to maintain the limits established by the motor manufacturers!

AC: $\Delta U = \sqrt{3} \times I \times l \times Z$
 DC: $\Delta U_1 = 2 \times I \times l \times R$

ΔU_1 = Voltage drop [V] R = Resistance [$\Omega/1000 \text{ m}$]
 ΔU_2 = Voltage drop in % l = Power feed length [m]
 I = Ampere load [A] L = System length [m]

l = L power feed located at the end of the system
 l = L/2 power feed located at the center of the system
 l = L/4 power feed located at both ends of the system
 l = L/6 power feed located at L/6 from each end of the system
 Z = Impedance [$\Omega/1000 \text{ m}$]
 V = Voltage rating [V]

The total ampere load is determined from the nominal rated current of all motors working simultaneously on the same feed section of your electrification system. A diversity factor of 0,5-0,9 can be considered.

The conductor size and/or number of feed points should be increased or booster cables should be used in parallel in case the drop is exceeding the limitations.

Technical Data

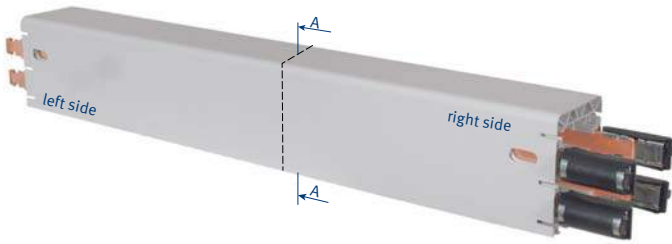

KBHF with spring loaded connectors

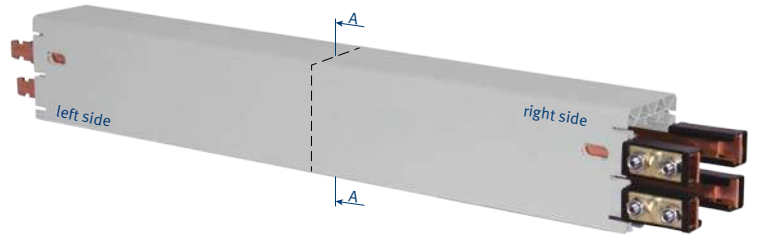

KBHS with bolted joints

Type ⁽¹⁾	HS with PE SS without PE	No. of conductors	Max. continuous current A at 35°C			Copper cross section mm ²				Nominal voltage V ⁽⁴⁾
			L1 L2 L3	60 % DC	80 % DC	100 % DC	L1 L2 L3		N / 5 ⁽²⁾	
KBHF										
KBHF 4 / 40 ... HS		4	52	45	40	3 x 10	10	-	-	690
KBHF 4 / 40 ... SS ⁽⁵⁾		4	52	45	40	-	-	-	4 x 10	690
KBHF 4 / 63 ... HS		4	81	70	63	3 x 14	14	-	-	690
KBHF 4 / 100 ... HS		4	129	112	100	3 x 26	26	-	-	690
KBHF 5 / 40 ... HS		5	52	45	40	3 x 10	10	10	-	690
KBHF 5 / 40 ... SS ⁽⁵⁾		5	52	45	40	-	-	-	5 x 10	690
KBHF 5 / 63 ... HS		5	81	70	63	3 x 14	14	14	-	690
KBHF 5 / 100 ... HS		5	129	112	100	3 x 26	26	26 ⁽³⁾	-	690
KBHS										
KBHS 4 / 40 ... HS		4	52	45	40	3 x 10	10	-	-	690
KBHS 4 / 40 ... SS ⁽⁵⁾		4	52	45	40	-	-	-	4 x 10	690
KBHS 4 / 63 ... HS		4	81	70	63	3 x 14	14	-	-	690
KBHS 4 / 100 ... HS		4	129	112	100	3 x 26	26	-	-	690
KBHS 4 / 125 ... HS		4	161	140	125	3 x 33	26	-	-	690
KBHS 4 / 160 ... HS		4	207	179	160	3 x 51	26	-	-	690
KBHS 4 / 200 ... HS		4	258	224	200	3 x 70	42	-	-	690
KBHS 5 / 40 ... HS		5	52	45	40	3 x 10	10	10	-	690
KBHS 5 / 40 ... SS ⁽⁵⁾		5	52	45	40	-	-	-	5 x 10	690
KBHS 5 / 63 ... HS		5	81	70	63	3 x 14	14	14	-	690
KBHS 5 / 100 ... HS		5	129	112	100	3 x 26	26	26 ⁽³⁾	-	690
KBHS 5 / 125 ... HS		5	161	140	125	3 x 33	26	26 ⁽³⁾	-	690
KBHS 5 / 160 ... HS		5	207	179	160	3 x 51	26	26 ⁽³⁾	-	690
KBHS 5 / 200 ... HS		5	258	224	200	3 x 70	42	26 ⁽³⁾	-	690

(1) ... Suffix types e.g. 2 m KBHF 4/63 with PE KBHF 4/63 - 2 HS Order-No. 600 012, shorter lengths are made up from the next larger standard length.

(2) In case of using a conductor as N see page 3.

(3) 5th. Conductor max. 80 A at 100% DC.

(4) Nominal voltage UL= 600 V

(5) control line

Technical Data

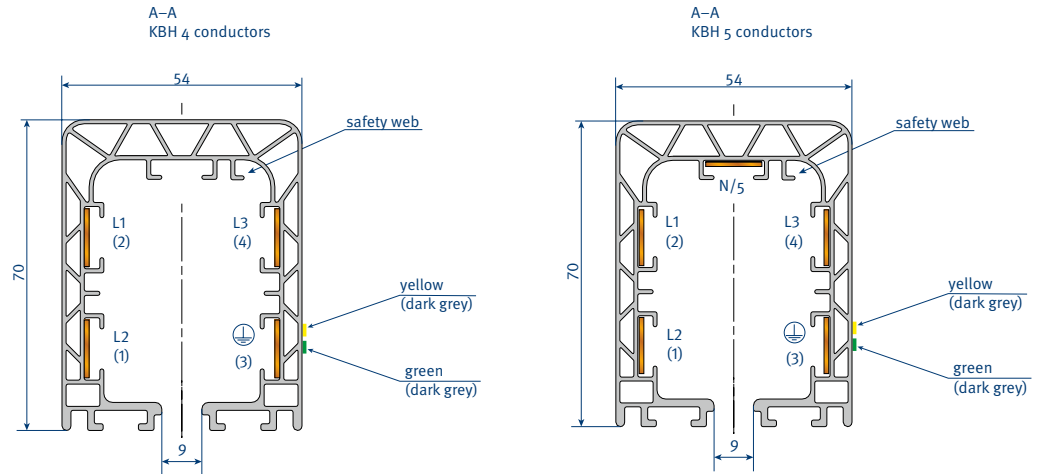

Numbers in paranthesis apply to control line

Leakage distance mm	Impedance at 50 Hertz and 20 °C $\Omega / 1000 \text{ m}$	Widerstand bei 20 °C $\Omega / 1000 \text{ m}$	Weight kg/m	Order-No. ⁽¹⁾
33	1,724	1,717	1,351	600 00•
33	1,724	1,717	1,351	600 03•
33	1,258	1,249	1,487	600 01•
33	0,702	0,687	1,903	600 02•
33	1,724	1,717	1,452	600 10•
33	1,724	1,717	1,452	600 13•
33	1,258	1,249	1,622	600 11•
33	0,702	0,687	2,142	600 12•
33	1,724	1,717	1,481	600 04•
33	1,724	1,717	1,481	600 09•
33	1,258	1,249	1,617	600 05•
33	0,702	0,687	2,033	600 06•
33	0,568	0,549	2,207	600 07•
30	0,376	0,351	2,699	600 08•
27	0,283	0,255	3,357	600 31•
33	1,724	1,717	1,614	600 14•
33	1,724	1,717	1,614	600 19•
33	1,258	1,249	1,784	600 15•
33	0,702	0,687	2,304	600 16•
33	0,568	0,549	2,479	600 17•
30	0,376	0,351	2,970	600 18•
27	0,283	0,255	3,628	600 32•

• The last number of the order specifies the section length. Please suffix the order number with 1, 2, 3, 4.

Ground = PE

Joining material, Hangers & End caps

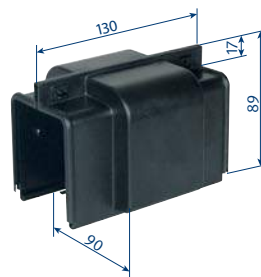

ready installed

Joint cap, self locking

Type	Weight kg	Order-No.
KVM	0,096	600 005



Sliding hanger at conductor section

Sliding hanger

Type ⁽¹⁾	Weight kg	Order-No.
KGA	0,100	600 000
KGA / K	0,100	600 397



Fixpoint hanger at conductor section

Fixpoint hanger

Type ⁽¹⁾	Weight kg	Order-No.
KFA	0,132	600 007
KFA / K	0,132	600 398

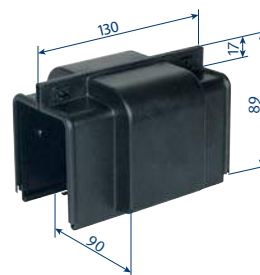

End cap ready installed

End cap left and right version

Type	Weight kg	Order-No.
KE	0,120	600 008

⁽¹⁾ .../K with stainless screws
All steel metal components

Brackets

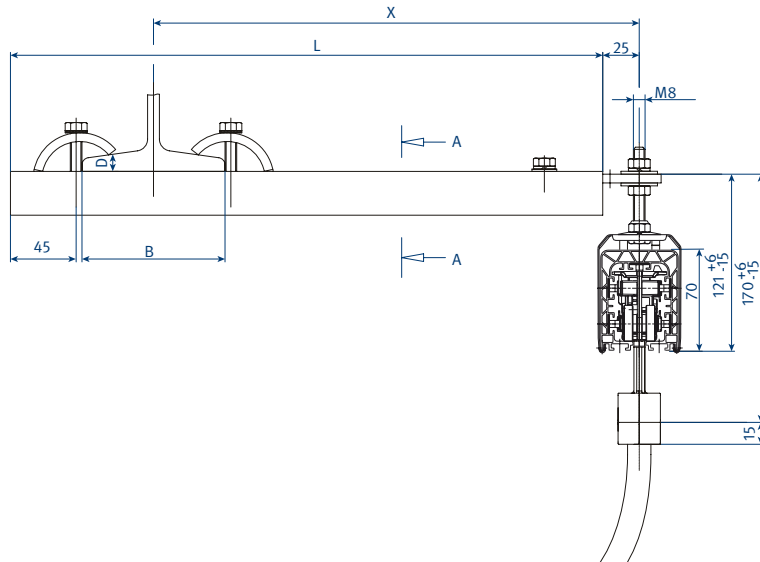
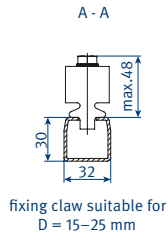
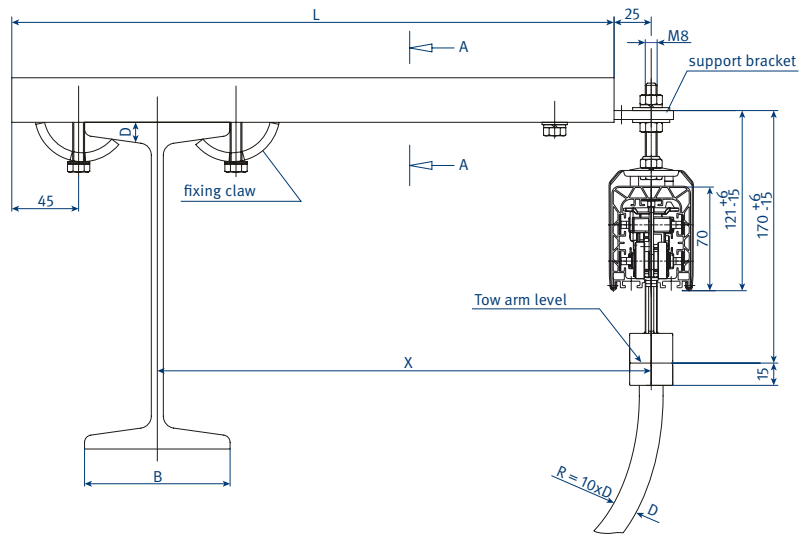
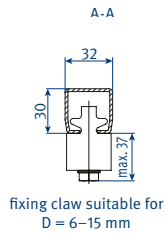

Arrangement EHK with small fixing claw

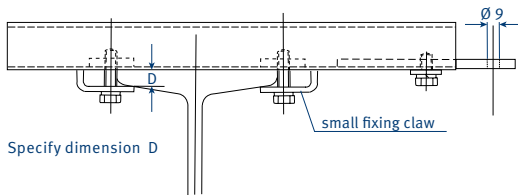

Attention!

Make sure that hoist wheels have enough clearance.
Use small claw if necessary.

Select next larger size bracket when your I-beam dimension B is more than 170 upto 300 mm.

□ - rail of EHK is identical to type S 1, Cat. 8 a

Type	X mm	L mm	B max. mm	Weight kg	Order-No. standard version	Order-No. with small fixing claw
EHK 250	250	350	170	1,070	251 600	251 720
EHK 300	300	400	170	1,150	251 610	251 730
EHK 400	400	500	170	1,300	251 620	251 740
EHK 500	500	600	170	1,450	251 630	251 750
EHK 600	600	700	170	1,600	251 640	251 760
EHK 700	700	800	170	1,750	251 650	251 770
EHK 750	750	850	170	1,820	251 660	251 780
EHK 800	800	900	170	1,900	251 670	251 790

End feeds, Line feeds

End feed (up to 63 A)

End feed comes loose without conductor section.
It can be mounted at the left or right hand side.
Electrical connection with customer supplied cable shoes to M6 terminals.
Max. connecting cross section 10 mm².

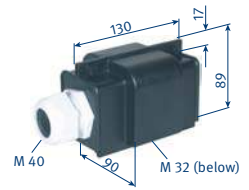

Type	Weight kg	Cable gland (Dimensions see page 13)	Order-No.
KKE 4 / 40-63 HS	0,218	M 40	600 010
KKE 5 / 40-63 HS	0,230	M 40	600 107
KKE 4 / 40 SS	0,196	M 32	600 015
KKE 5 / 40 SS	0,208	M 32	600 108

End feed (uo to 100 A)

End feed comes loose without conductor section.
It can be mounted at the left or right hand side.
Electrical connection with customer supplied cable shoes to M6 terminals.
Max. connecting cross section 35 mm².

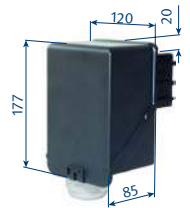

Type	Weight kg	Cable gland (Dimensions see page 13)	Order-No.
KKE 4 / 40-100 HS	0,570	M 32 oder M 50 ⁽¹⁾	600 422
KKE 5 / 40-100 HS	0,610	M 32 oder M 50 ⁽¹⁾	600 423

Line feed (at joint, 40-63 A)

KSE type comes loose without conductor section.
It can be mounted at any joint.
Electrical connection with customer supplied cable shoes to M6 terminals.

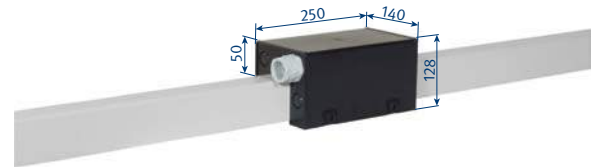

Typ	Gewicht kg	Cable gland (Dimensions see page 13)	Order-No.
KSE 4 / 40 HS	0,756	M 25	600 030
KSE 4 / 63 HS	0,776	M 32	600 035
KSE 5 / 40 HS	0,812	M 25	600 037
KSE 5 / 63 HS	0,832	M 32	600 038
KSE 4 / 40 SS	0,756	M 25	600 028
KSE 5 / 40 SS	0,812	M 25	600 029

Line feed (at joint, 100 A)

KSE type comes loose without conductor section.
It can be mounted at any joint.
Electrical connection with customer supplied cable shoes to M6 terminals.

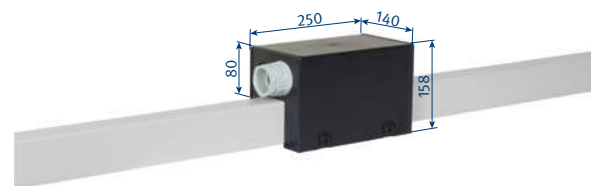

Type	Weight kg	Cable gland (Dimensions see page 13)	Order-No.
KSE 4 / 100 HS	0,908	M 50	600 036
KSE 5 / 100 HS	0,964	M 50	600 039

Feeds in the curve area on request.
(1) Both cable glands are attached to the packing unit.

Line feeds

Line feed (incl. 1 m section, 40–100 A)

With spring loaded connector.

Electrical connection with customer supplied cable shoes to M6 terminals.

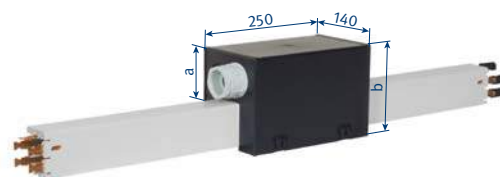

Type	Weight kg	Dimension		Cable gland (Dimensions see page 13)	Order-No.
		a	b		
KEF 4 / 40 HS	2,099	50	128	M 25	600 197
KEF 4 / 63 HS	2,255	50	128	M 32	600 199
KEF 5 / 40 HS	2,256	50	128	M 25	600 205
KEF 5 / 63 HS	2,446	50	128	M 32	600 207
KEF 4 / 100 HS	2,803	80	158	M 50	600 201
KEF 5 / 100 HS	3,098	80	158	M 50	600 209
KEF 4 / 40 SS	2,099	50	128	M 25	600 195
KEF 5 / 40 SS	2,256	50	128	M 25	600 203

Line feed (incl. 1 m section, 40–125 A)

With bolted joints.

Electrical connection with customer supplied cable shoes M6 terminals to 100 A, with M8 terminals to 125 A.

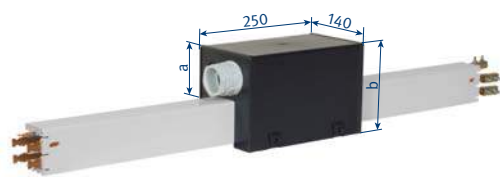

Type	Weight kg	Dimension		Cable gland (Dimensions see page 13)	Order-No.
		a	b		
KES 4 / 40 HS	2,229	50	128	M 25	600 221
KES 4 / 63 HS	2,385	50	128	M 32	600 223
KES 5 / 40 HS	2,413	50	128	M 25	600 229
KES 5 / 63 HS	2,608	50	128	M 32	600 231
KES 4 / 100 HS	2,933	80	158	M 50	600 225
KES 4 / 125 HS	3,251	80	158	M 50	600 045
KES 5 / 100 HS	3,260	80	158	M 50	600 233
KES 5 / 125 HS	3,606	80	158	M 50	600 049
KES 4 / 40 SS	2,229	50	128	M 25	600 219
KES 5 / 40 SS	2,418	50	128	M 25	600 227

Feeds in the curve area on request.

Line feed & Terminal Box

Line feed

including 1m section (125 - 200 A) with 2m single cores

Electrical connection with customer supplied cable shoes to M 6 terminals. See below.

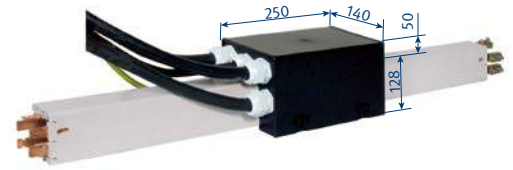

Type	Weight kg	Cable cross section in sqmm / Diam. in mm			Order-No.
		L1-L3	Ground	N / 5	
KELS 4 / 125 HS	8,560	35 / 16	25 / 10	-	600 069
KELS 4 / 160 HS	9,784	50 / 18	25 / 10	-	600 075
KELS 4 / 200 HS	11,400	70 / 21	35 / 11	-	600 385
KELS 5 / 125 HS	9,372	35 / 16	25 / 10	25 / 15	600 077
KELS 5 / 160 HS	10,596	50 / 18	25 / 10	25 / 15	600 079
KELS 5 / 200 HS	12,212	70 / 21	35 / 11	25 / 15	600 387

Terminal Box (for KELS, 125–200 A)

Electrical connection with customer supplied cable shoes.

Clamping range 16-95 mm².

View „A“ Input of the single cores of the KELS (a.m.)

View „B“ with M 63 (Dimensions see page 13)

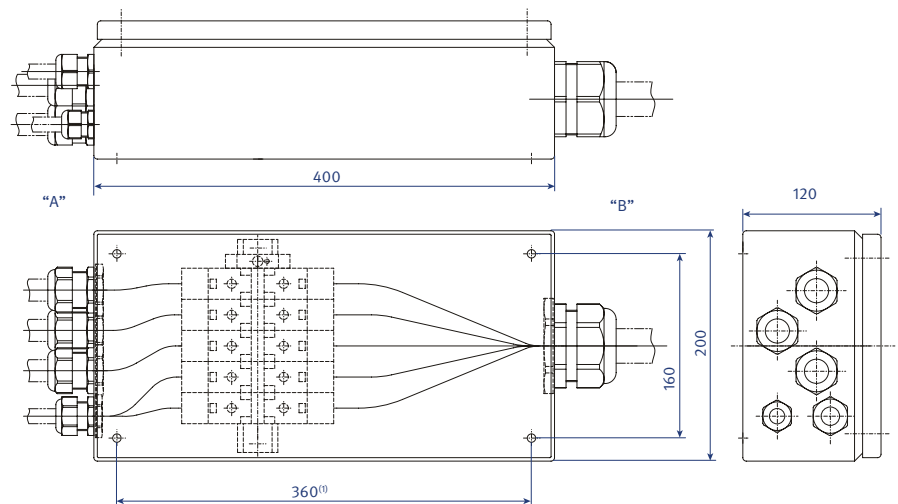

Type	Weight kg	for line feed	Order-No.
ZK 1	5,030	KELS 4 / 125 HS	600 389
ZK 2	5,040	KELS 4 / 160–200 HS	600 390
ZK 3	5,370	KELS 5 / 125 HS	600 391
ZK 4	5,380	KELS 5 / 160–200 HS	600 392

Feeds in the bow area on request.

(1) Fixing borings ø 7 mm at the bottom of the box.

Curves, Sealing strip & Cable glands for feeds

Curves

Production corresponding to customer drawing

Min. horizontal bending radius	40–125 A	= 600 mm
	160 A	= 1000 mm
	200 A	= on request
max. \curvearrowright 120°		
min. bending radius, vertical		= 2000 mm
max. curved length		= 3600 mm

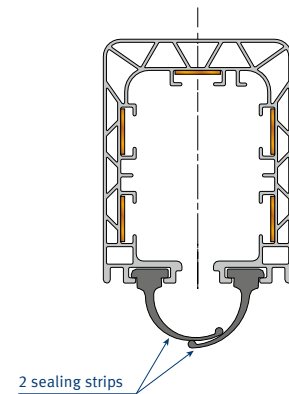
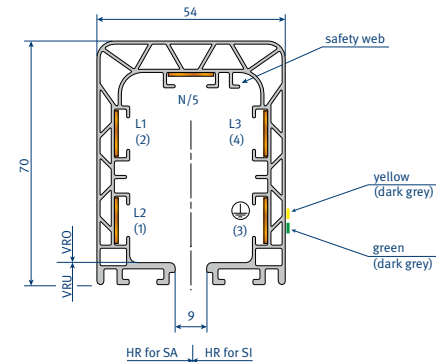

Horizontal curve for SI and SA

Vertical curve for VRO and VRU

SI = Safety-web inside
SA = Safety web outside

VRO = Vertical radius upwards
VRU = Vertical radius downwards

Safety web will be mounted in direction of track.
Changes in measurements of curves have to be mentioned for replacement orders.

Sealing strip (including accessories)

Type	Order-No.
Sealing strip ⁽¹⁾	600 551
Fixing clamp for sealing strip (1 per end)	600 354
Coupling for sealing strip (2 for each joint)	258 300
Mounting glider for sealing strip	600 109
Sealing strip slide plate for collectors KSW	600 640

Cable glands for feeds

for type	Cable gland	for cable diam. in mm	Power rating in A	Page
KKE	M50	27–35	40 –100 HS	10
KKE	M40	17–28	40 / 63 HS	10
KKE	M32	15–21	40 SS	10
KSE/KEF/KES	M25	9–19	40 HS / SS	10 und 11
KSE/KEF/KES	M32	17–26	63 HS	10 und 11
KSE/KEF/KES	M50	23–34	100 HS	10 und 11
KES	M50	29–40	125 HS	11
ZK 1–4 (Seite B)	M63	27–48	125 / 160 / 200 HS	12

⁽¹⁾ The max. single length is 40 m long. For further distances are joint laces necessary.
For each meter system length have 2 m sealing strip to be ordered. The delivery will be in pairs.

Heating

Type	Resistance ⁽²⁾	Order-No.
Heating cable: H 0,15	0,15 Ω/m	196 382
Heating cable: H 0,20	0,20 Ω/m	196 383
Heating cable: H 0,32	0,32 Ω/m	196 384
Heating cable: H 0,38	0,38 Ω/m	196 385
Heating cable: H 0,48	0,48 Ω/m	196 386
Heating cable: H 0,60	0,60 Ω/m	196 387
Heating cable: H 0,81	0,81 Ω/m	196 389
Heating cable: H 1,00	1,00 Ω/m	196 390
Heating cable: H 1,44	1,44 Ω/m	196 391
Heating cable: H 2,00	2,00 Ω/m	196 392
Heating cable: H 3,00	3,00 Ω/m	196 393

We recommend a heating system for outdoor installations and conductor systems in humid plants. The heating consists of two heating cables which are arranged according to the illustration beside.

Attention: Switch on heating system below + 5 °C ambient temperature.

The type of heating cable has to be calculated: heat output per heating cable between 20 - 25 W/m.

For longer heating distances the total length has to be divided into different heating sections.

For shorter heating distances to feed with lower secondary voltage via transformer.

Construction of the heating cable: Heating resistor made of CrNi (different conductors)
 Isolation of heating cable PTFE (Teflon)
 Nickel-plated copper netting
 Sheath PTFE-Isolation

Outer diameter:

3,7mm - 4,3 mm

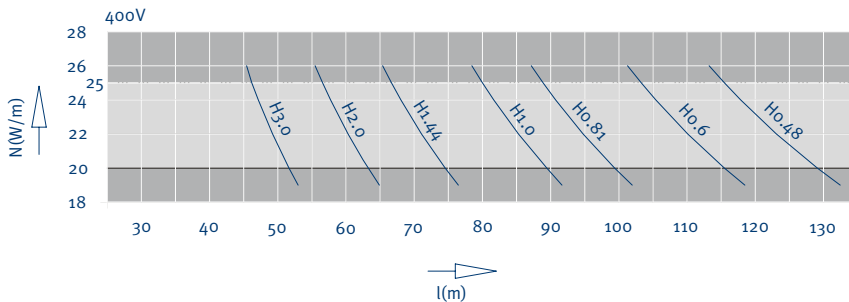
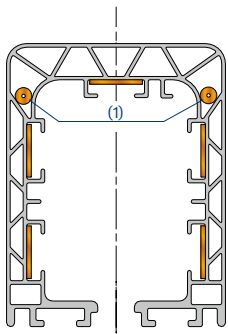

$$\text{Heating capacity Watt/m: } N' = \frac{U^2}{R \cdot L^2}$$

U = Supply voltage (Volt)
 R = Resistance of heating cable (Ohm/m)
 L = Length of heating section (m)

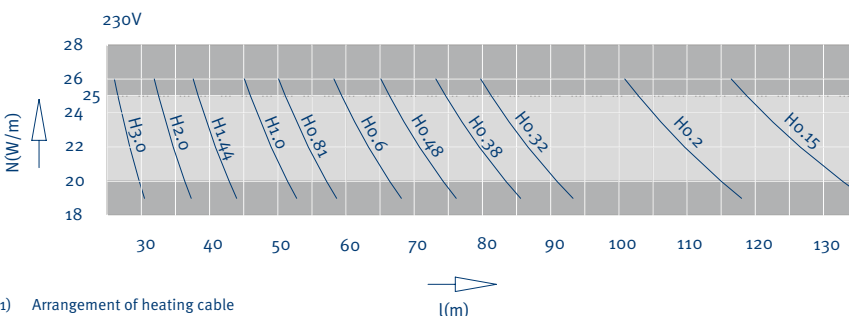

- (1) Arrangement of heating cable
 (2) Deflection ± 2,5%

Heating

Layout examples (depending on system situation)

a) 2 heating circuits

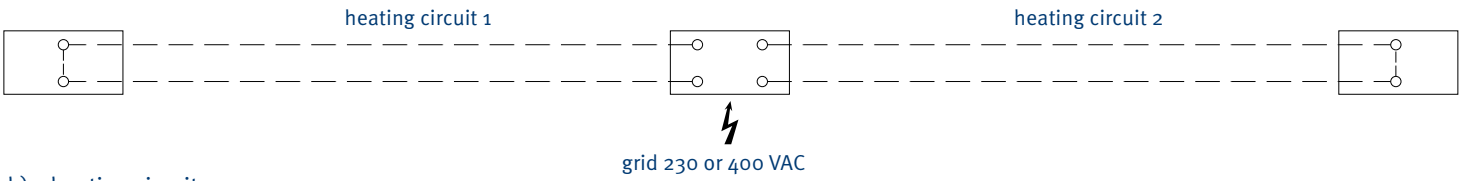

b) 1 heating circuit

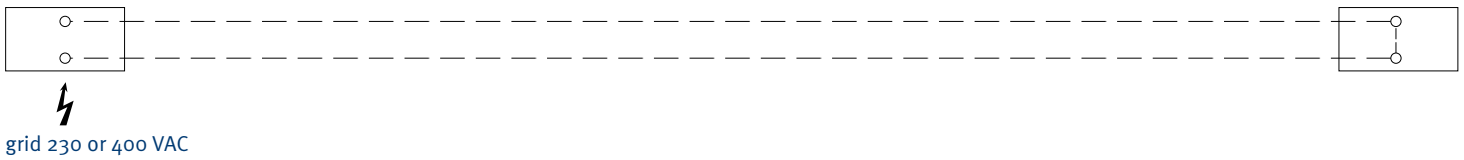

c) 2 heating circuits

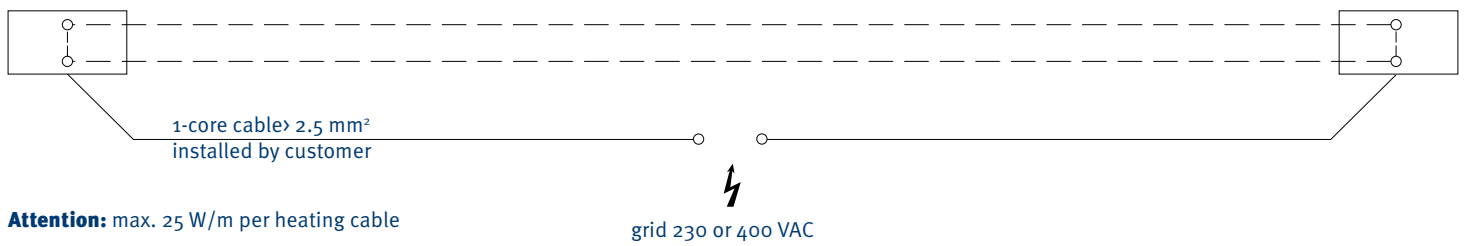

Attention: max. 25 W/m per heating cable

Terminal
box

Terminal boxes for heating

Type	Version	Cable gland Measurements see page 13	Order-No.
Terminal box	left end	M25	600 155
Terminal box	right end	M25	600 156
Terminal box	line feed	2 x M25	600 065
1 set material for connecting clamps			195 291

For each end feed box 2 sets of material for connecting ends are required.
For line feed you need 4 sets of material for connection ends.

Order for 60 m powerail - example c)

- 1) 122 m heating cable type H 2,0
(2 x 60 m and 2 x 1 m additional)
Voltage 400 V, two heating circles parallel
heating capacity as per above mentioned diagramm
2 x 22 W/m at 60 m 2 x 22 W/m ~2640 W = 2,64 kW.
- 2) 1x Junction box left end
1x Junction box right end
- 3) 4x sets of material for connection ends.

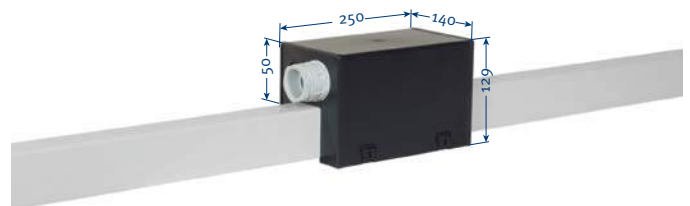

Switch gear assembly and temperature control unit as per customers inquiry.
Fuses, cables etc. have to be provided by the customer.

Contact sections, turntables & switches

Contact section⁽¹⁾

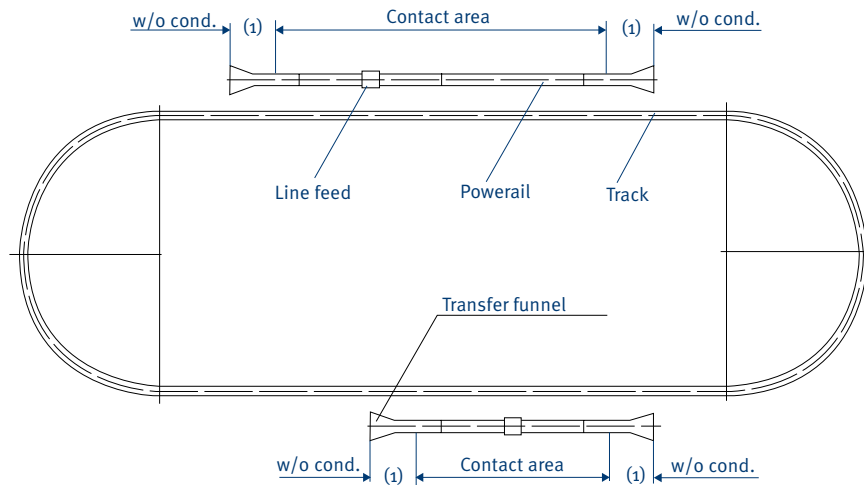

Turntable

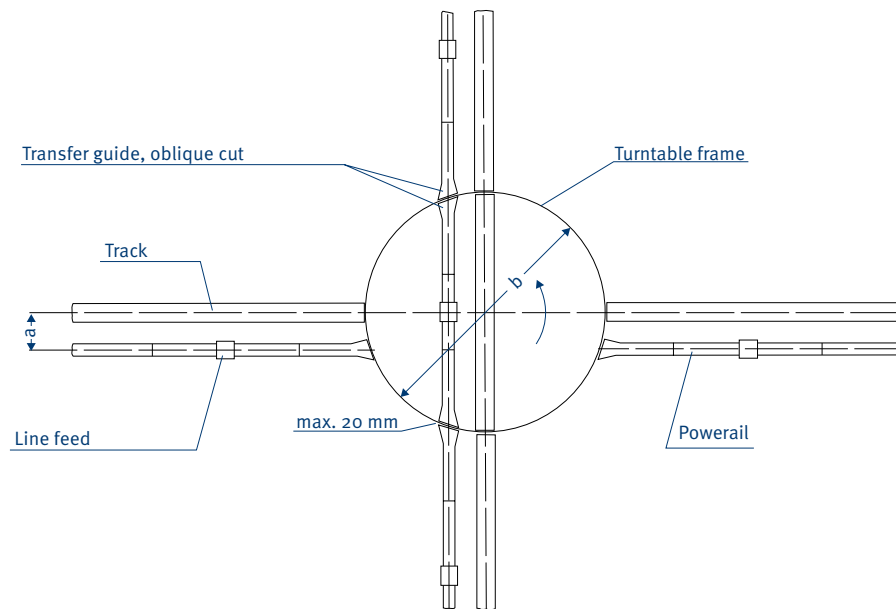

Switch

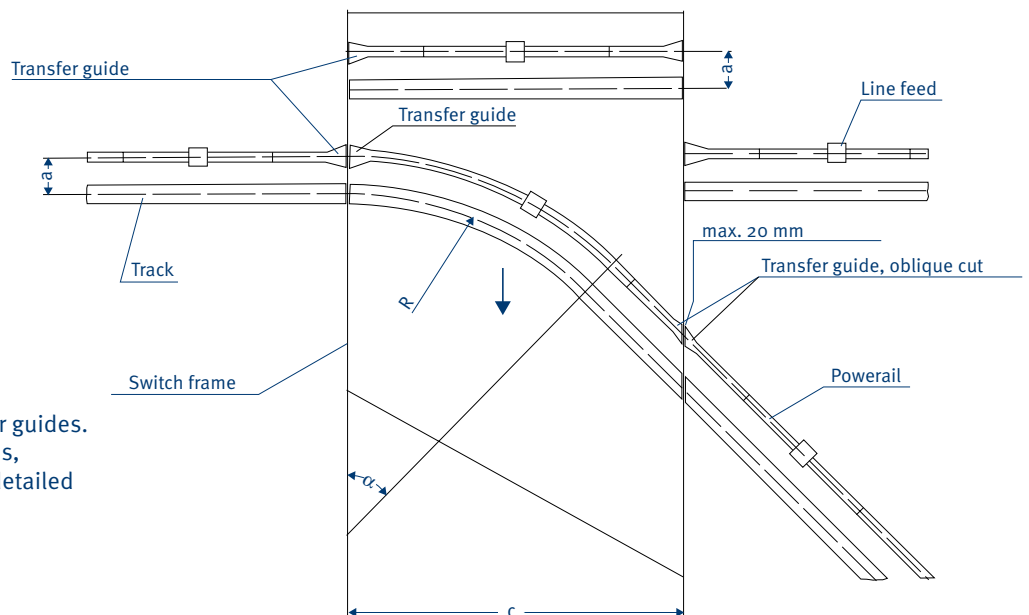

Please submit drawings of transfer applications. Specify dimensions a, b, c, R and angle α ($\alpha = \text{max. } 50^\circ$)

Max. 20 mm air gap between transfer guides. To create all parts for contact sections, turntables and switches we require detailed construction drawings.

⁽¹⁾ Contact sections must not be activated before collectors are fully engaged.

Transfer funnels & Transfer guides

Transfer funnel

Conductor system should not be activated before the collector carbons have complete contact with the conductors.

Offset: max. 10 mm horizontal
max. 10 mm vertical

Max. speed for crossover of the current collector 60 m/min.
Hints for dimensioning the left-and right hand version refer to page 6 and 7.

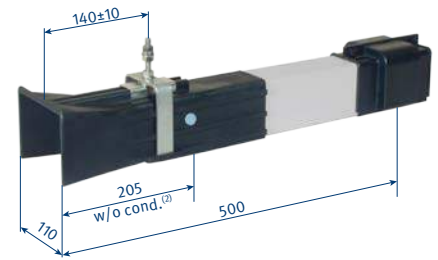

Type ⁽¹⁾	Weight kg	Order-No.	
		left version	right version
KET 4 / 40–125 ... HS	1,612	600 285	600 279
KET 4 / 160 ... HS	1,724	600 286	600 280
KET 4 / 200 ... HS	1,943	600 305	600 303
KET 5 / 40–125 ... HS	1,720	600 228	600 282
KET 5 / 160 ... HS	1,858	600 289	600 283
KET 5 / 200 ... HS	2,128	600 306	600 304
KET 4 / 40 ... SS	1,612	600 287	600 281
KET 5 / 40 ... SS	1,720	600 290	600 284

Transfer guides, straight

Necessary with all types of double collectors or 2 single collectors.

Staggered arrangement of the transfer guides to each other: max. 5 mm horizontal
max. 3 mm vertical

Max. speed for crossover of the current collector 80 m/min.
Hints for dimensioning the left-and right hand version refer to page 6 and 7.

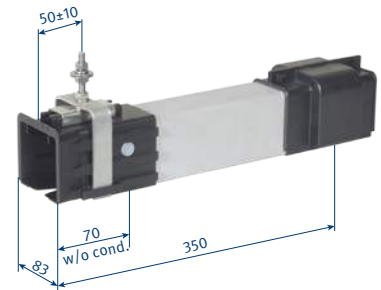

Type ⁽¹⁾	Weight kg	Order-No.	
		left version	right version
KÜ 4 / 40–125 ... HS	1,348	600 261	600 255
KÜ 4 / 160 ... HS	1,448	600 262	600 256
KÜ 4 / 200 ... HS	1,640	600 309	600 307
KÜ 5 / 40–125 ... HS	1,500	600 264	600 258
KÜ 5 / 160 ... HS	1,625	600 265	600 259
KÜ 5 / 200 ... HS	1,865	600 310	600 308
KÜ 4 / 40 ... SS	1,348	600 263	600 257
KÜ 5 / 40 ... SS	1,500	600 266	600 260

(1) Add types e.g. KET 4/40-125...HS Left hand version KET 4/40-125 L HS Order-No. 600 285.
(2) Corresponding to the center of collector

Transfer guides & Conductor dead section

Transfer guides, oblique

Necessary with all types of double collectors or 2 single collectors.

Staggered arrangement of the transfer guides to each other: max. 5 mm horizontal
max. 3 mm vertical

Measurements (oblique) and angle to be specified by customer

Max. speed for crossover of the current collector 80 m/min.

Hints for dimensioning the left and right hand version refer to page 6 and 7.

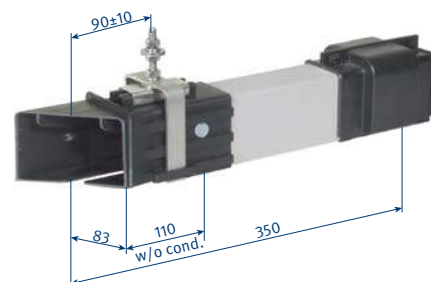

Type ⁽¹⁾	Weight kg	Order-No.	
		left version	right version
KÜS 4 / 40–125 ... HS	1,312	600 273	600 267
KÜS 4 / 160 ... HS	1,396	600 274	600 268
KÜS 4 / 200 ... HS	1,560	600 317	600 315
KÜS 5 / 40–125 ... HS	1,450	600 276	600 270
KÜS 5 / 160 ... HS	1,555	600 277	600 271
KÜS 5 / 200 ... HS	1,760	600 318	600 316
KÜS 4 / 40 ... SS	1,312	600 275	600 269
KÜS 5 / 40 ... SS	1,450	600 278	600 272

(1) Add types e.g. KÜS 4/40-125...HS Left hand version KÜS 4/40-125 L HS Order-No. 600 267

Conductor dead section

Please advise us which conductors should be disconnected (see Page 6 and 7). The dead section comes factory assembled.

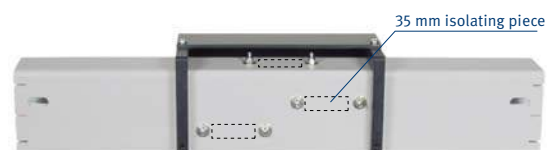

Picture shows a isolating piece.

Air gap 5 mm		Isolating piece 35 mm	
Type	Order-No.	Type	Order-No.
KTL 1	600 298	KTI 1	600 293
KTL 2	600 299	KTI 2	600 294
KTL 3	600 300	KTI 3	600 295
KTL 4	600 301	KTI 4	600 296
KTL 5	600 302	KTI 5	600 297

Removing section

Removing section (incl. 1m conductor section) with special bolted joints for KBHF and KBHS on both ends. Assembly and disassembly of the collector is possible at the end of the track as well as at the removing section.

By opening and closing the sliders at the bottom of the removing section housing the collector can be mounted and demounted easily.

Before opening disconnect mains.

The removing section does not disconnect the conductor system electrically.

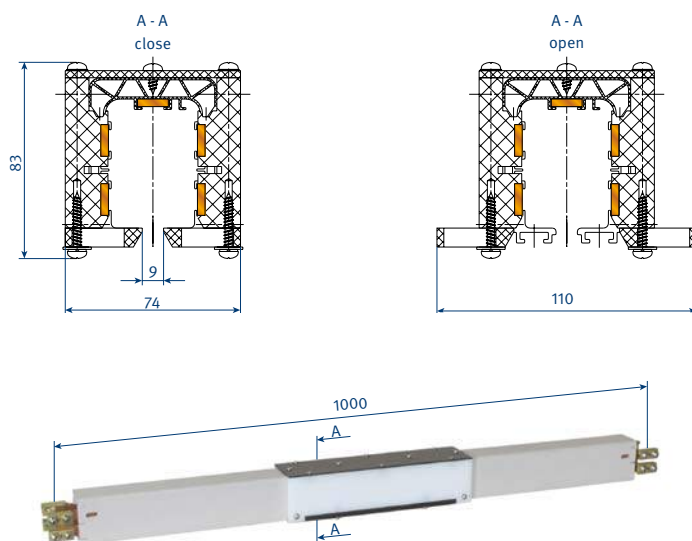

For single collectors

Type	Weight kg	Order-No.
KAT 4 / 40-125 HS	3,450	600 165
KAT 4 / 160 HS	3,802	600 166
KAT 4 / 200 HS	4,494	600 327
KAT 5 / 40-125 HS	3,781	600 167
KAT 5 / 160 HS	4,133	600 168
KAT 5 / 200 HS	4,825	600 328
KAT 4 / 40 SS	3,450	600 169
KAT 5 / 40 SS	3,781	600 170

For double collectors

Type	Weight kg	Order-No.
KATD 4 / 40-125 HS	4,044	600 175
KATD 4 / 160 HS	4,396	600 176
KATD 4 / 200 HS	5,088	600 329
KATD 5 / 40-125 HS	4,375	600 177
KATD 5 / 160 HS	4,727	600 178
KATD 5 / 200 HS	5,419	600 330
KATD 4 / 40 SS	4,044	600 179
KATD 5 / 40 SS	4,375	600 180

Anti-Condensation section

Anti-condensation section

with special bolted joints for KBHF and KBHS at both ends.

Application of Anti-condensation section

The anti-condensation section will be used where conductor systems are passing from indoor to outdoor, preventing condensation of the outside mounted conductor section. The warm air from indoors can escape through the anti condensation section (see sketch). The anti-condensation section does not interrupt the conductor system electrically.

Additional feeds are not required.

Assembly

The anti-condensation section is to be placed directly (0,5m - 1m max.) at the transfer point from indoor to outdoor. See sketch.

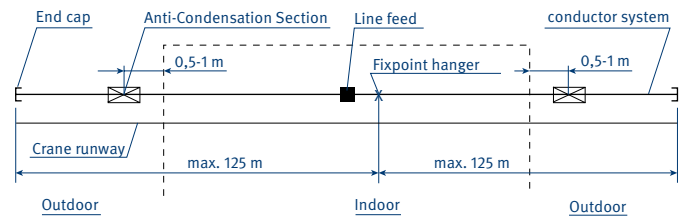
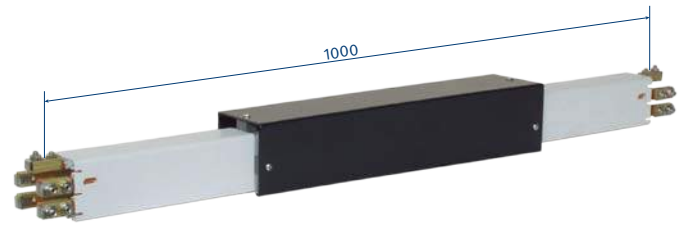

Type	Weight kg	Order-No.
KBT 4 / 40-125 HS	3,858	600 185
KBT 4 / 160 HS	4,210	600 186
KBT 4 / 200 HS	4,902	600 319
KBT 5 / 40-125 HS	4,180	600 188
KBT 5 / 160 HS	4,532	600 189
KBT 5 / 200 HS	5,224	600 320
KBT 4 / 40 SS	3,858	600 187
KBT 5 / 40 SS	4,180	600 190

Expansion section

Expansion section

The Expansion sections are required to compensate the different expansions between copper conductors and steel- or concrete structures, in varying temperatures without interrupting electrical power.

Expansion joints are used when the conductor length between feeds, curves, switches or other fix points is exceeding 20 m.

Max. length during differences in temperature:

Δt 90 °C (-30 °C bis +60 °C)

install one expansion joint per 100 m.

An additional expansion joint every 100 m.

Arrangement of fixpoints according to sketches.

The remaining conductor sections have to be arranged in sliding hangers.

Additional feeds or current collectors are not required as the expansion-sections do not interrupt electrical power.

Assembly

The gap dimension „a“ is 75 mm and is valid for an ambient temperature of -10 °C to +35 °C during installation.

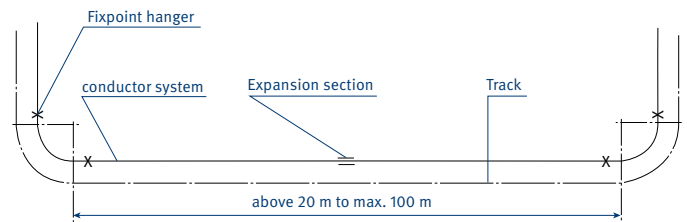
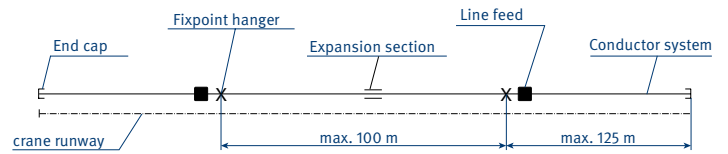
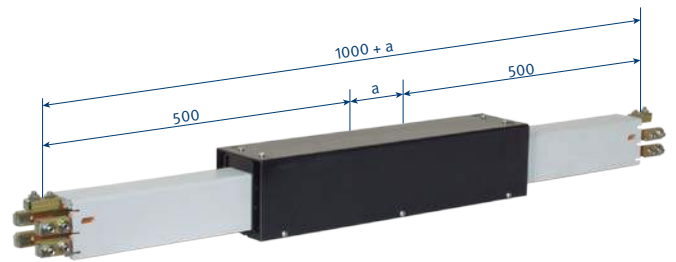

Type	Weight kg	Order-No.
KD 4 / 40–125 HS	4,400	600 135
KD 4 / 160 HS	4,752	600 136
KD 4 / 200 HS	5,444	600 325
KD 5 / 40–125 HS	4,895	600 138
KD 5 / 160 HS	5,247	600 139
KD 5 / 200 HS	5,939	600 336
KD 4 / 40 SS	4,400	600 137
KD 5 / 40 SS	4,895	600 140

Single Current collector

Collector KSW

max. speed 150 m/min.

For conductor systems with sealing strip up to 100 m/min.

Connecting cable:

for 25 A with 2,5 mm²/core

for 40 A with 4,0 mm²/core

for 60 A with 6,0 mm²/core

1 m long, longer cables on request.

Cleaning collector on request.

Order example for a 2 m long cable

Order-No. 600 096-2 for collector KSW 4/40-2 HS

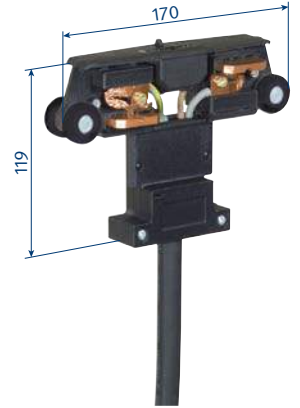

Type	weight kg	No. of conductors	Power rating at 60 % DC in A	approx. diam. of connecting-cables in mm	Order-No.
KSW 4 / 25-1 HS	0,552	4	25	13,0	600 095
KSW 4 / 40-1 HS	0,656	4	40	15,0	600 096
KSW 4 / 60-1 HS	0,797	4	60 ⁽¹⁾	17,0	630 066
KSW 5 / 25-1 HS	0,634	5	25	14,0	600 098
KSW 5 / 40-1 HS	0,771	5	40	17,0	600 099
KSW 5 / 60-1 HS	0,945	5	60 ⁽¹⁾	19,0	600 413
KSW 4 / 25-1 ST	0,472	4	25	11,0	600 097
KSW 5 / 25-1 ST	0,534	5	25	12,0	600 100

Collector KSWs

max. speed 250 m/min.

For conductor systems with sealing strip up to 100 m/ min.

Connecting cable:

for 25 A with 2,5 mm²/core

for 40 A with 4,0 mm²/core

for 60 A with 6,0 mm²/core

1 m long, longer cables on request.

Order example for a 2 m long cable

Order-No. 600 149-2 for collector KSWs 5/40-2 HS

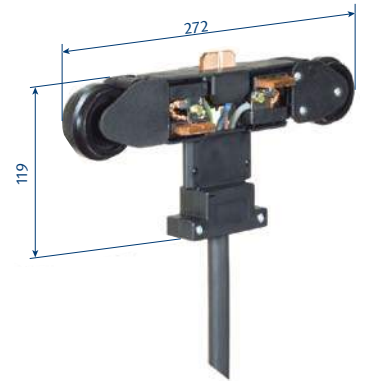

Type	Weight kg	No. of conductors	Power rating at 60 % DC in A	approx. diam. of connecting-cables in mm	Order-No.
KSWs 4 / 25-1 HS	0,664	4	25	13,0	600 145
KSWs 4 / 40-1 HS	0,768	4	40	15,0	600 146
KSWs 4 / 60-1 HS	0,942	4	60 ⁽¹⁾	17,0	600 416
KSWs 5 / 25-1 HS	0,724	5	25	13,5	600 148
KSWs 5 / 40-1 HS	0,861	5	40	16,0	600 149
KSWs 5 / 60-1 HS	1,035	5	60 ⁽¹⁾	19,0	600 417
KSWs 4 / 25-1 ST	0,584	4	25	11,0	600 147
KSWs 5 / 25-1 ST	0,624	5	25	12,0	600 150

(1) at 40% DC

Double collector & Tow arms

Double collector DKSW (max. speed 150 m/min.)

Also for conductor systems with sealing strip up to 100 m/min.

The double collectors are supplied as an assembly kit consisting of 2 collectors (KSW) and a connecting bar with mounting material.

For the collector KSWs there are no double collectors available 2 single collectors must be used instead.

Connecting cable:

for 50 A with (2x) 2,5 mm²/core

for 80 A with (2x) 4,0 mm²/core

for 120 A with (2x) 6,0 mm²/core

1 m long, longer cables on request.

Order example for 2 m long cables

Order-No. 600 119-2 for collector DKSW 5/80-2 HS

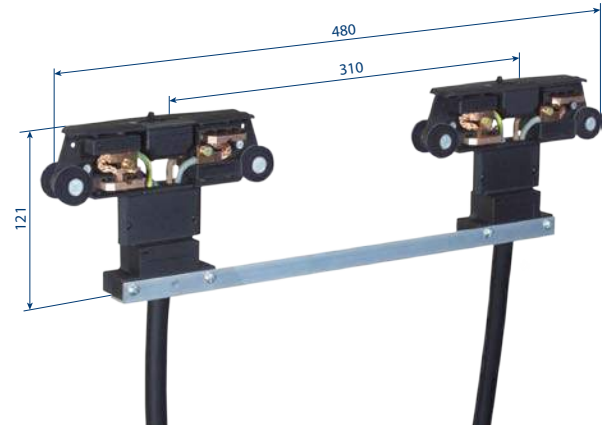

Type	Weight kg	No. of conductors	Power rating at 60 % DC in A	approx. diam. of connecting-cables in mm	Order-No.
DKSW 4 / 50-1 HS	1,170	4	50	12,5	600 115
DKSW 4 / 80-1 HS	1,378	4	80	14,5	600 116
DKSW 4 / 120-1 HS	1,660	4	120 ⁽¹⁾	17,0	600 414
DKSW 5 / 50-1 HS	1,334	5	50	13,5	600 118
DKSW 5 / 80-1 HS	1,608	5	80	16,0	600 119
DKSW 5 / 120-1 HS	1,956	5	120 ⁽¹⁾	19,0	600 415
DKSW 4 / 50-1 ST	1,010	4	50	11,0	600 117
DKSW 5 / 50-1 ST	1,134	5	50	12,0	600 120

Tow arm

Installation options of 30 mm square-, hollow profile or tube with 30 - 34 mm

A-A
Version with square hollow profile (without adapter plate)



A-A
Version with tube⁽²⁾

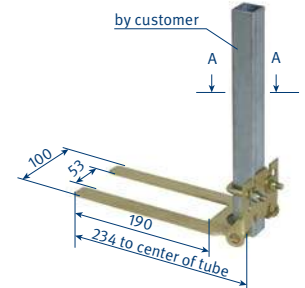

Type	Weight kg	Order-No.
MGU	0,550	600 334
MGU / K ⁽³⁾	0,550	600 336

Tow arm

Installation option for plane surface

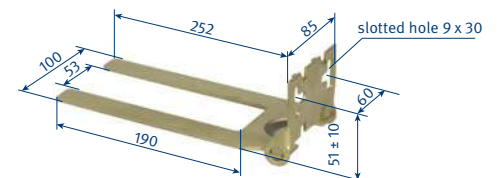

Type	Weight kg	Order-No.
MGF	0,510	600 335
MGF / K ⁽³⁾	0,510	600 337

(1) At 40% DC

(2) For assembly use enclosed adapter plate

(3) Stainless steel

Flexible tow arm

Flexible tow arm

Flexible support type for single collector for installations with transfer funnels type KET (see page 13). Measurements for installation see below. If you are going to use the flexible towing arm in system with curves please contact us.

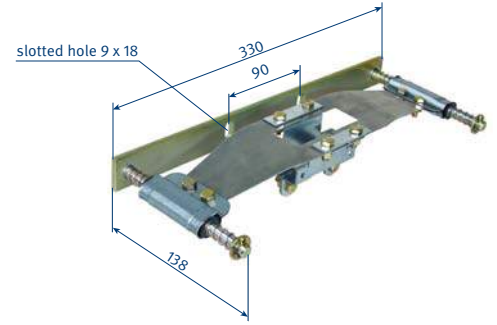

Type	Weight kg	Order-No.
KFMHN	0,790	600 558

Arrangement of a flexible tow arm

KFMHN with collector type KSW

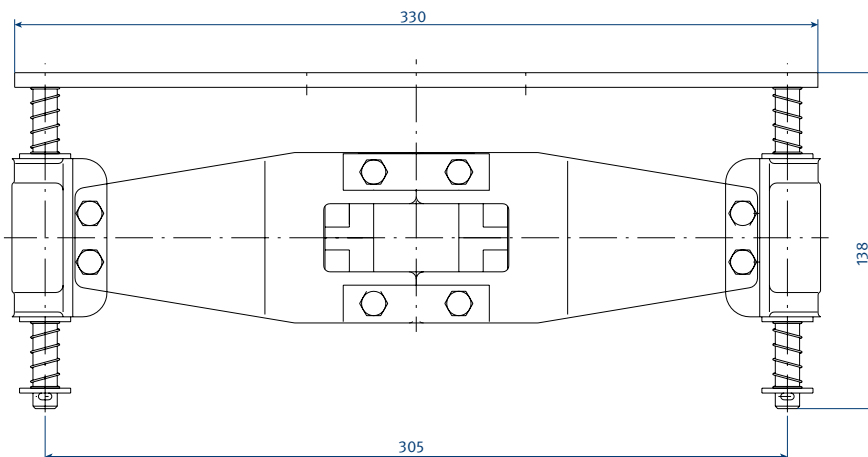
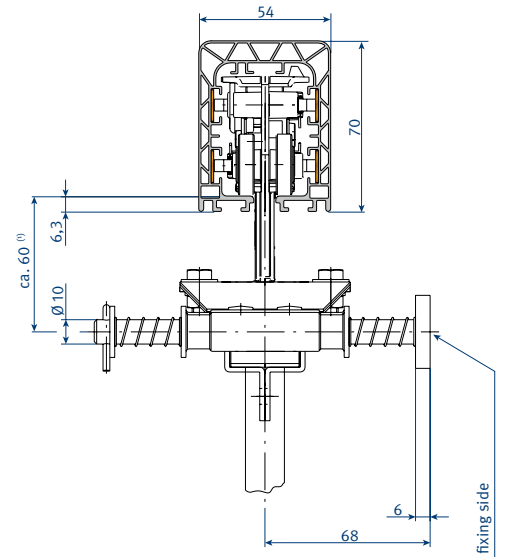
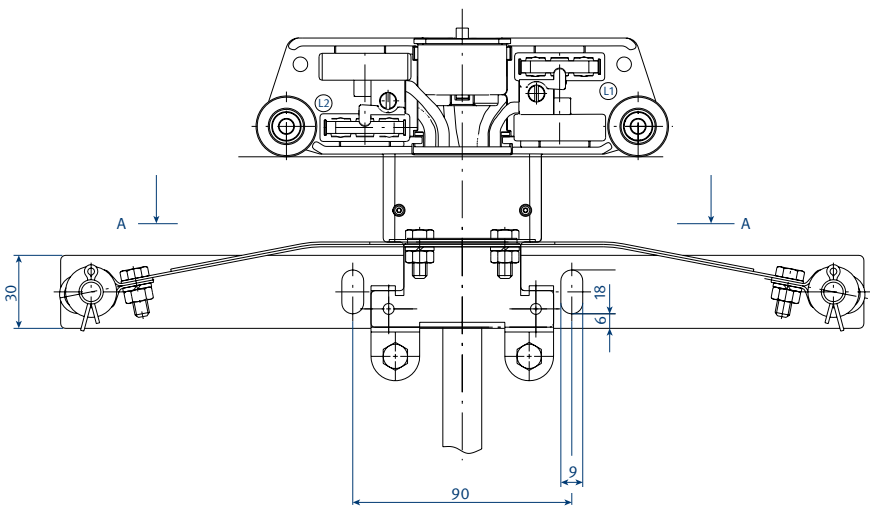

max. horizontal offset 10 mm
max. vertical offset 10 mm

(i) To be fixed during installation.

Examples for ordering

Installation length of 64 m KBH... (configuration see page 6 and 7)

Quantity	Article	KBHF 4 / 63 HS with end feed		KBHF 5 / 100 HS mit with line feed		KBHS 5 / 160 HS with line feed incl. 1m conductor section	
		Type	Order-No.	Type	Order-No.	Type	Order-No.
16	conductor section, 4 m long	KBHF 4/63-4 HS	600 014	KBHF 5/100-4 HS	600 124	-	-
15	conductor section, 4m long	-	-	-	-	KBHS 5/160-4 HS	600 184
1	conductor section, 3m long	-	-	-	-	KBHS 5/160-3 HS	600 183
1	End feed	KKE 4/40-63 HS	600 010	-	-	-	-
1	Line feed	-	-	KSE 5 / 100 HS	600 039	-	-
1	Line feed 1m long	-	-	-	-	KELS 5/160 HS	600 079
1	End cap	KE	600 008	-	-	-	-
2	End cap	-	-	KE	600 008	KE	600 008
15	Joint cap	KVM	600 005	-	-	-	-
14	Joint cap	-	-	KVM	600 005	-	-
16	Joint cap	-	-	-	-	KVM	600 005
1	Fixpoint hanger	KFA	600 007	KFA	600 007	KFA	600 007
32	Sliding hanger	KGA	600 000	KGA	600 000	KGA	600 000
1	Current collector	KSW 4/40-1 HS	600 096	KSW 5/40-1 HS	600 099	KSW 5/40-1 HS	600 099
1	Tow arm	MGU	600 334	MGU	600 334	MGU	600 334

Examples for ordering

Installations with curves as per customer drawing

41,075 m conductor system KBHF 4/63 consisting of:

Quantity	Article	KBHF 4 / 63		KBHS 5/63	
		Type	Order-No.	Type	Order-No.
7	Conductor system, 4m long	KBHF 4/63-4 HS	600 014	KBHS 5/63-4 HS	600 154
1	Conductor system, 4 m long for 1 x 3500 mm short length	KBHF 4/63-4 HS	600 014	KBHS 5/63-4 HS	600 154
1	Conductor system, 3 m long for 1 x 2610 mm short length	KBHF 4/63-3 HS	600 013	KBHS 5/63-3 HS	600 153
1	Conductor system, 2 m long for horizontal curve 45°, R = 2100 mm, L = 1648 mm, SA	KBHF 4/63-2 HS	600 012	KBHS 5/63-2 HS	600 152
2	Conductor system, 3 m long for horizontal curve 2 x 45°, R = 2700 mm, L = 2121 mm, SI	KBHF 4/63-3 HS	600 013	KBHS 5/63-3 HS	600 153
1	End feed	KKE 4/40-63 HS	600 010	KKE 5/40-63 HS	600 107
1	Expansion section	KD 4/40-125 HS	600 135	KD 5/40-125 HS	600 138
11	Joint cap	KVM	600 005	KVM	600 005
4	Fixpoint hanger	KFA	600 007	KFA	600 007
24	Sliding hanger	KGA	600 000	KGA	600 000
1	End cap	KE	600 008	KE	600 008
1	Current collector	KSW 4/40-1 HS	600 096	KSW 5/40-1 HS	600 099
1	Tow arm	MGF	600 335	MGF	600 335

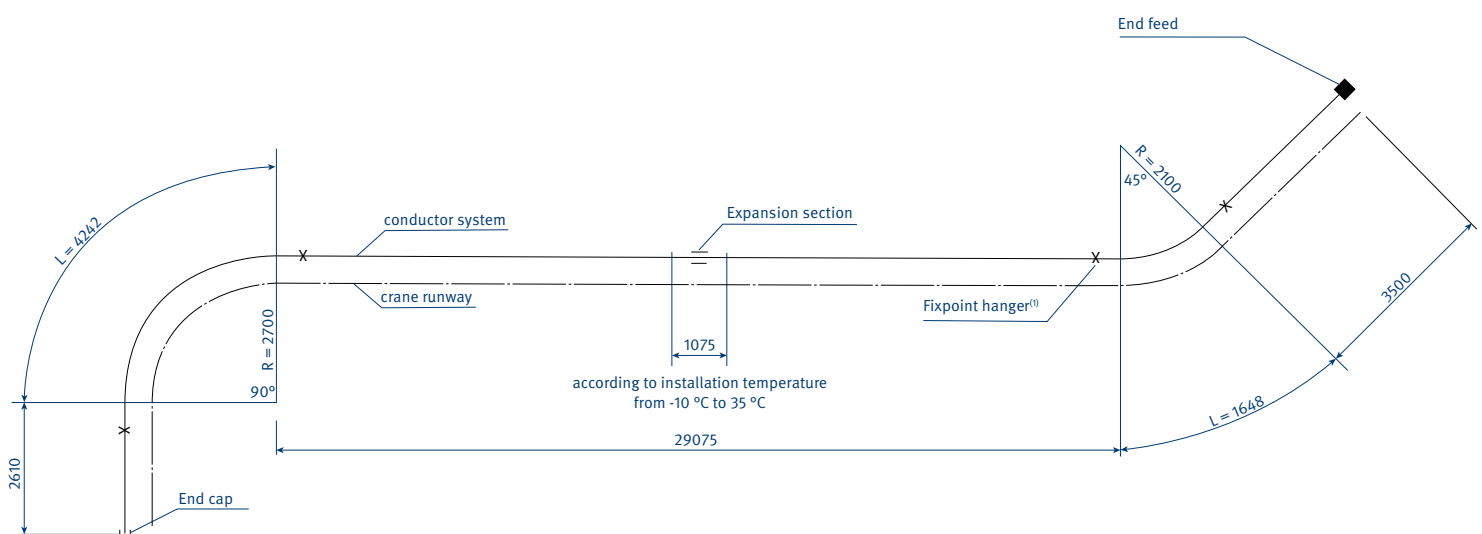

⁽¹⁾ Rest of conductor system to be installed with sliding hangers

Spare part list

Spare part list for conductor system

Type	KBHF	KBHS
	Order-No.	Order-No.
Joint cap (pair)	600 005	600 005
Spring loades connector 40–100A	600 483	-
Bolted joints 40–160A	-	262 018
Bolted joints 200A	-	600 712
Neoprene sealing strip, in pairs (max. length 40m each)	600 551	600 551
Coupling for sealing strip, in pairs (for lengths < 40m each)	258 300	258 300
Fixing clamp for sealing strip (1 per end)	600 354	600 354
Mounting glider for sealing strip (> 10m system length)	600 109	600 109
Feed terminal for end feed (40/63A)	600 006	600 006
Feed terminal for line feed (lateral)	600 017	600 017
Feed terminal for line feed (on top, 5th conductor)	600 016	600 016

Spare part list for current collector

Type	KSW/DKSW	KSWS
	Order-No.	Order-No.
Carbon brush phase (lateral)	600 088	600 088
Carbon brush 5th conductor (top)	600 089	600 089
Carbon brush ground (lateral PE)	600 090	600 090
Carbon pressure spring (standard), suitable for all carbon brushes	600 338	600 338
Connecting bar for double collector DKSW	600 105	
Assembly kit (to convert KSW KSWS)		600 106
Sealing strip slide plate for collectors KSW	600 640	600 640

Questionnaire

Company: _____ Date: _____

Fon: _____ Fax: _____

eMail: _____ Internet: _____

1. Number of conductor system installations: _____

2. Type of equipment to be powered: _____

3. Operating voltage: _____ Volt Frequency: _____ Hz

Three phase voltage: _____ AC voltage: _____ DC voltage: _____

4. Track length: _____

5. Number of conductors: _____ neutral: _____ control: _____ ground: _____

6. Mounted position of conductor system:

Conductor system pendant, collector cable facing to the bottom Conductor system pendant, lateral payout of conductor cable⁽¹⁾

Support distance _____ m (max. 2m)

other: _____

7. Number of consumers per system: _____

8. Indoor: _____ Outdoor: _____

9. Other operating conditions (humidity, dust, chemical influence, etc.) _____

10. Ambient temperature: _____ °C min. _____ °C max.

11. Hall expansion joints: _____ pieces expansion min.: _____ expansion max.: _____

12. Position and number of feeding points⁽¹⁾: _____

13. Position and number of isolating sections (e.g. for maintenance)⁽¹⁾: _____

14. How will the conductor be arranged?⁽¹⁾: _____

15 Brackets required: yes no c/c distance beam/conductor system: _____

16. Travel speed: _____ m/min. in curves: _____ m/min. at transfers: _____ m/min.

17. Max. voltage drop from the conductor system feed point to the consumer considering starting current.

18. Power consumption of the individual consumer loads: _____

Motor data	Crane 1							Crane 2						
	Power kW	Nominal current			Starting current		Type of Motors ⁽²⁾	Power kW	Nominal current			Starting current		Type of Motors ⁽²⁾
		A	cos φ _N	% DC	A	cos φ _A			A	cos φ _N	% DC	A	cos φ _A	
Hoist motors														
Auxiliary hoist														
Long travel														
Cross travel														

Mark with * those motors which can run simultaneously.

Mark with those motors which can start up simultaneously.

Further remarks: _____

⁽¹⁾ For curved tracks, powerail with isolating sections etc., we require sketches to enable us to prepare a quotation

⁽²⁾ Use: K for squirrel cage motor, S for slipring motor, F for frequency controlled motor

We reserve all rights to make alterations in the interests of further development

Please copy and fill in the questionnaire

Signature _____

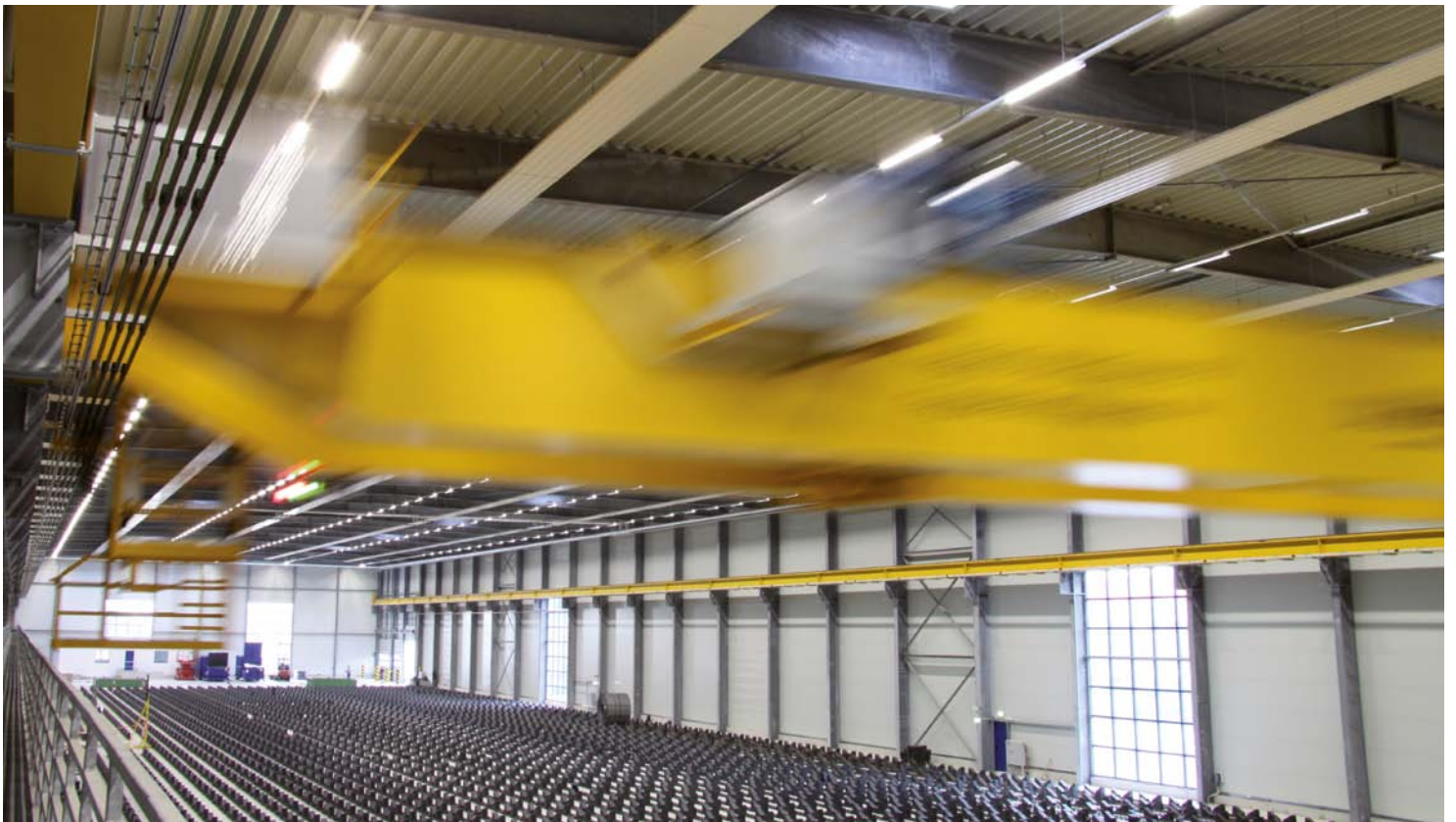





Products and Service

Catalog No.

1 Open conductor systems	
Open conductor systems	1a
2 Insulated conductor systems	
U10	2a
FABA 100	2b
U15, U25, U35	2c
U20, U30, U40	2d
3 Compact conductor systems	
VKS 10	3a
VKS - VKL	3b
4 Enclosed conductor systems	
KBSL - KSL	4a
KBH	4b
MKH	4c
LSV - LSVG	4d
5 Contactless power supply	
Contactless power supply (CPS®)	5a
6 Data transmission	
VAHLE Powercom®	6a
Slotted Microwave Guide (SMG)	6b
7 Positioning systems	
VAHLE APOS®	7a
VAHLE APOS Optic	7b
8 Festoon systems and cables	
Festoon systems for □-tracks	8a
Festoon systems for flat cables on I-track	8b
Festoon systems for round cables on I-track	8c
Festoon systems for ◇-track	8d
Cables	8e
9 Reels	
Spring operated cable reels	9a
Motor powered cable reels	9b
10 Other	
Battery charging systems	10a
Heavy enclosed conductor systems	10b
Tender	10c
Contact wire	10d
Assemblies / Commissioning	
Spare parts / Maintenance service	



certified by DQS according to Din EN
ISO 9001:2008 OHSAS 18001:2007
(Reg. Nr. 003140 QM 08/BSOH)